



WOLF Ex-PENLITE PL-01

ATEX Directive
94/9/EC Compliant



- Uniform illumination for close proximity work
- Pen-size pocket portability
- High quality robust brass construction
- Explosion-protected to new ATEX directive
- High energy alkaline cells Certified
- Single handed switch operation



Ex-Penlite PL-01
0.56w wide angle beam (approx 30°)
Peak luminous intensity at 1m **9 lux**, at 2.5m **2 lux**

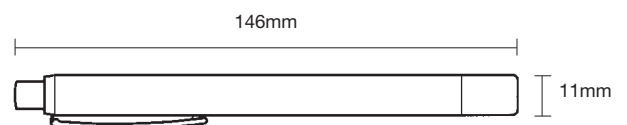
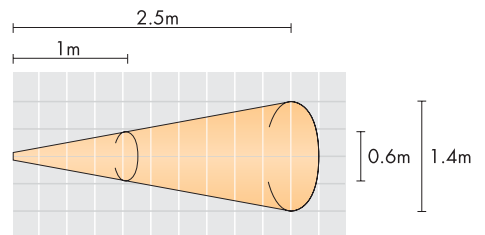

The Wolf Ex-Penlite PL-01 is a small, robust light source, certified for safe use in potentially explosive atmospheres. It is ideal for use in many hazardous area applications, such as gas meter reading, and by systems and instrument engineers as an essential and convenient mini-torch for close inspection and maintenance work. It can also be provided as an escape light for personnel in confined spaces if faced with an emergency situation.

Approved by German test house TÜV, the Wolf Ex-Penlite is CE marked in compliance with the 94/9/EC Explosive Atmospheres (ATEX) Directive for use in a wide range of potentially explosive atmospheres. The Wolf Ex-Penlite has been approved to Apparatus group IIC, allowing use in all potentially explosive gases, vapours and mists, up to T4 temperature class, in zone 1 & 2 (category 2) hazardous areas.

The Wolf Ex-Penlite has a brass body with satin plated finish, and a threaded lens cap with plastic lens, removable for bulb and battery replacement. A push button switch is fitted on the end for easy, single handed, operation. A pen clip is also incorporated in the design, allowing the Ex-Penlite to be securely retained in a pocket, and

preventing roll on a flat surface. Electro-static hazards are avoided with the use of a metal body.

Utilising a 2.25V, 0.25A lensed bulb, the Wolf Ex-Penlite emits an excellent uniform, wide angled beam, ideally suited to short distance work. Approvals allow the use of all R03 (AAA) standard and specified LR03 high power alkaline cells; alkaline cells providing a

continuous duration of up to five hours. Use of rechargeable cells is prohibited.

The Wolf Ex-Penlite is supplied complete with cells, an EC Declaration of Conformity and user instructions. A copy of the Wolf Ex-Penlite EC Type Examination Certificate is available upon request.

Wolf Ex-Penlite PL-01 Technical Specification		
Product reference	PL-01	
Product description	Safety penlite, primary cell powered	
Code	Ⓔ II 2 G EEx e ia IIC T4	
Apparatus standards	EN 50014, EN 50019, EN 50020	
Equipment category	2G	
Type of protection	'e' increased safety, 'ia' intrinsic safety	
Apparatus classification	zones 1 & 2, gas groups IIA, IIB and IIC	
Temp. classification	T4	
Ambient temperature	-20°C to +40°C	
Certification	TÜV00ATEX1529	
Enclosure	brass, plated	
Lens	plastic	
Beam type	wide angle	
Light source:	Wolf Pt. no.	PL-11
	Type	Vacuum filament bulb, lensed, Type 222
	Volts	2.25V
	Watts (amps)	0.56W (0.25A)
	Output	5 lm
	Life	5 hrs
Power source:	Wolf Pt. no.	LT-401 x 2
	Type	AAA primary cells (LR03 recommended)
	Volts	2 x 1.5v
Light duration	5 hrs	
Ingress Protection	IP54 minimum	
Weight (incl. cells)	60 g	

Note: All information has been gathered under laboratory conditions, the user must regard the values given as approximate. The Company reserves the right to alter product specifications without prior notice.

WOLF SAFETY LAMP COMPANY

Saxon Road Works, Sheffield S8 0YA, England

Tel: +44 114 255 1051 Fax: +44 114 255 7988

E-mail: info@wolf-safety.co.uk Website: www.wolf-safety.co.uk

MMD/N/.4.03/6K



WOLF MINI & MICRO TORCHES



Primary Cell Mini Safety Torches

- Ultra small size
- T4 and T5 temperature class versions
- Zone 0 certified LED models
- Simple, robust design with integral clip
- Single handed switching
- Ingress protection to IP67



Ref	M-10	M-20	M-40	M-60
	II 1 G Ex ia IIC T5 IP67			
	II 2 G Ex ib IIC T4 IP67			
	II 1 G Ex ia IIC T4 IP67			
	II 1 G Ex ia IIC T4 IP67			
	Baseefa06ATEX0084			
G	Zone 0, 1 & 2	Zone 1 & 2	Zone 0, 1 & 2	Zone 0, 1 & 2
D	-			
	25g	60g		
	22 x 70mm	22 x 146mm		
	4 x LR44	2 x LR03 (AAA)	3 x LR1 (N)	
	1x5mm LED	1.05W Xenon	3x5mm LED	1W LED
	=1.7 hrs	=2.3 hrs	=6 hrs	=4 hrs
	IP67			

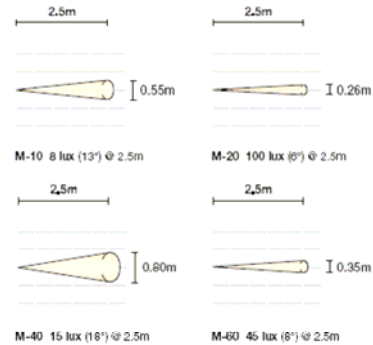

Model	MicroLite M-10	MiniLite M-20	MiniLite M-40	MiniLite M-60	
	LED Micro Torch	Xenon Mini Torch	LED Mini Torch	1 watt LED Mini Torch	
Code	II 1 G Ex ia IIC T5 (Tamb=50°C)	II 2 G Ex ib IIC T4	II 1 G Ex ia IIC T4 (Tamb=50°C)	II 1 G Ex ia IIC T4	
Equipment Category	1 G	2 G	1 G	1 G	
Apparatus Standard	EN50020, EN60079-0				
Type of Protection	Intrinsic Safety				
Area of Classification (gas)	Zones 0, 1 & 2	Zones 1 & 2	Zones 0, 1 & 2	Zones 0, 1 & 2	
Temperature Class (gas)	T5	T4			
Ambient Temperature	-20°C to + 50°C	-20°C to + 40°C	-20°C to + 50°C	-20°C to + 40°C	
Certificate	Baseefa06ATEX0084				
Enclosure	Impact resistant thermoplastic, electrostatic non-hazardous				
Lens	Polycarbonate				
Beam Type	Medium Spot	Narrow Spot	Medium Spot	Medium Spot	
Light Source	Part No.	-	M-201	-	
	Type	1x5mm LED White	Xenon filled filament bulb	3 x 5mm LED White	
	Rating	-	2.3V 0.3A	-	
	Output	18 cd	15 lumens	3 x 18 cd	30 lumens
	Life	50,000 hours	30 hours	50,000 hours	50,000 hours
Power Supply	Part No.	4 x M-102	2 x M-202	3 x M-402	
	Type	LR44 primary cells to IEC60086	LR03 primary cells to IEC60086	LR1 primary cells to IEC60086	
	Volts	4 x 1.5V	2 x 1.5V	3 x 1.5V	
Light Duration	2 hours	2.3 hours	10 hours	10 hours	
Ingress Protection	IP67 to EN60529:1992				
Weight (including cells)	25gms	60gms	60gms	60gms	



WOLF ATEX SAFETY TORCHES



- T6 and T4 models
- Simple, robust design
- Ultimate halogen light output
- High energy alkaline cell certified
- ATEX explosive gas and dust approval
- Low power indicator option



TS-26 & TR-26
1.2W beam (approx 5°)
Peak luminous intensity at 5m, **170 lux**

TS-24 & TR-24
1.7W beam (approx 5°)
Peak luminous intensity at 5m, **230 lux**

TS-24+ & TR-24+
2.0W beam (approx 5°)
Peak luminous intensity at 5m, **280 lux**

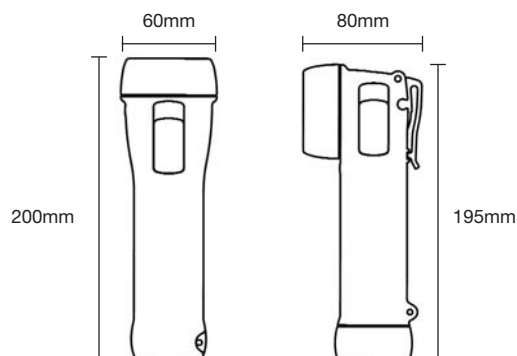
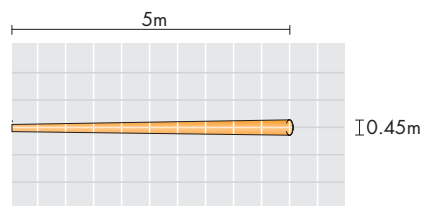

The Wolf ATEX Safety Torch range offers the perfect answer for every Ex application, with reliable, simple and cost effective solutions. The range includes T4 and T6 models with straight or right-angle body style.

T4 models give outstanding light output using advanced, long life halogen or xenon bulbs, set in a high quality parabolic reflector, coupled with alkaline cell approval, giving up to 12 hours of light output. The T4 halogen models are fitted with a low power warning circuit, illuminating a red indicator when battery voltage is low. Alternatively T6 approval allows use in any Zone 1 or 2 atmospheres, with optimum light output in this temperature class, and a 5 hour duration.

The Wolf ATEX Torch range is CE marked compliant with the 94/9/EC ATEX Explosive Atmospheres Equipment Directive. BASEEFA Certification is to the latest standards, for use in potentially explosive gas, vapour and mist atmospheres, zones 1 and 2, temperature class T6 or T4. Dust ignition protection covers use in zones 21 and 22, with the certified maximum surface temperatures of 65°C or 95°C. Temperature ambient use is from – 20°C to a maximum of 40°C or 55°C, as specified in the instructions.

The compact Wolf ATEX Torch design has a high-grip ergonomic form with easy single handed switching, even with gloved hands. The torch body offers high strength,

and proven impact resistance even at sub zero temperatures, using carefully selected thermoplastic resins with excellent chemical resistance. Additionally, the rubber armoured lens ring and end cap give enhanced grip and shock protection. The shatterproof polycarbonate lens has a scratch and chemical resistant coating. The Wolf ATEX Torch range is sealed dust tight and protected from water immersion, with a certified IP67 enclosure. Right angle models incorporate a replaceable high strength thermoplastic belt clip for hands free use. Both models allow straightforward battery and bulb replacement, a spare bulb is fitted in the bulbholder for quick and convenient replacement. All models are supplied with wrist straps and clip rings.

Wolf ATEX Safety Torches						
Technical Specification						
Model	TS-26	TR-26	TS-24	TR-24	TS-24+	TR-24+
Description	Safety Torch, Primary Cell Powered, Straight or Right-Angle					
	Straight T6	R/Angle T6	Straight T4	R/Angle T4	Straight T4+ with indicator	R/Angle T4+ with indicator
Code	Ⓔ II 2 GD EEx e ib IIC T6 IP67 T65°C		Ⓔ II 2 GD EEx e ib IIC T4 (Tamb = 40/55°C) IP67 T95°C (Tamb = 55°C)			
Equipment category	2 GD					
Apparatus standard	EN50014, EN0019, EN50020, EN50281-1-1					
Type of protection	Increased safety, intrinsic safety					
Area of classification (gas)	Zones 1 & 2 Gas Groups IIA, IIB, IIC					
Temperature class (gas)	T6			T4		
Ambient temperature (gas)	-20°C to +40°C			-20°C to +40°C/+55°C		
Area of classification (dust)	Zones 21 and 22					
Temperature class (dust)	65°C			95°C		
Ambient temperature (dust)	-20°C to +40°C			-20°C to +55°C		
Certificate	BAS 02 ATEX 2220X					
Enclosure	Impact resistant thermoplastic, electrostatic non-hazardous					
Lens	Polycarbonate, impact resistant with hard coat					
Beam type	Medium spot					
Light source:	Pt. no.	TP-406		TP-404		TP-402
	Type	Vacuum filament bulb		Xenon filled filament bulb		Halogen filled filament bulb
	Rating	2.4V, 0.5A		2.4V, 0.7A		2.4V, 0.83A
	Output	11.4 lm (at nom voltage)		15 lm (at nom voltage)		23 lm (at nom voltage)
	Life	15 hrs		50 hrs		30 hrs
	Spare bulb	TP-406		TP-404		TP-404
Power supply	Pt. no.	T-20		H-20		
	Type	R20 primary cells to IEC60086		R20/LR20 primary cells to IEC60086		
	Volts	2 x 1.5v		2 x 1.5v		
Light duration	Up to 5 hrs		Up to 12 hrs		Up to 10 hrs	
Ingress protection	IP67 to EN60529: 1992					
Weight (without cells)	150g	190g	150g	190g	150g	190g

Note: All information has been gathered under laboratory conditions, the user must regard the values given as approximate. The Company reserves the right to alter product specifications without prior notice.

WOLF SAFETY LAMP COMPANY

Saxon Road Works, Sheffield S8 0YA, England

Tel: +44 114 255 1051 Fax: +44 114 255 7988

E-mail: info@wolf-safety.co.uk Website: www.wolf-safety.co.uk

MMD/N/.8.02/2K



Wolf Safety Lamp Company



WOLF INTRINSICALLY SAFE TORCH



- **Unique Variable Beam Adjustment**
- **Modular Construction for Flexible Options**
- **Twin Concept Ex. Enclosure**
- **Self Re-locking Bulb Enclosure**
- **0.5A High Efficiency Krypton or Xenon Bulb**
- **Moulded in High Impact Thermoplastic Resin**
- **Right angle models with clip available for 'hands-free' operation**
- **CE marked to ATEX Directive**



T-2DC & T-2DCRA

1.2w variable beam

Peak luminous intensity for spot beam (approx 4.5°) at 5m **200lux**

Peak luminous intensity for wide beam (approx 25°) at 5m **30lux**

T-3DC & T-3DCRA

1.8w variable beam

Peak luminous intensity for spot beam (approx 4.5°) at 5m **300lux**

Peak luminous intensity for wide beam (approx 25°) at 5m **40lux**

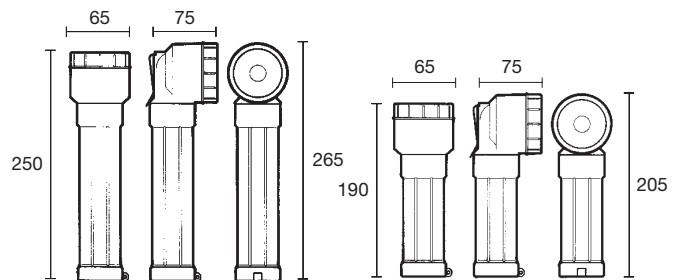
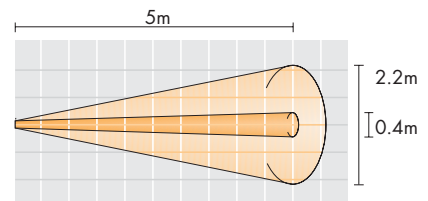

The Wolf Intrinsically Safe Torch range comprises four models designed to meet a wide scope of requirements. The robustly constructed torches are moulded in high impact thermoplastic resin for lasting durability and service requirements. Compact and simple to use, the torches are designed for use in potentially explosive atmospheres, emergency situations or wherever the need arises for a handheld safety torch.

The range complies with the 94/9/EC ATEX Directive as Category 2 equipment, and is approved to the latest European "EN" Standards for "Electrical apparatus for potentially explosive atmospheres". This allows for use in Group II applications, Zones 1 and 2, IIA and IIB gases where T4 temperature class permits.

Common uses are in Fire-fighting as Breathing Apparatus (BA) torches, Gas distribution, Water treatment, and wherever explosive gases and vapours accumulate in confined spaces.

A unique and highly acclaimed feature of the torches is the Optical Focusing System. The parabolic mirror is computer designed to provide variable beam adjustment from a powerful spot to broader floodlit illumination, through the high impact lens.

The torches are available as two cell straight head (T-2DC), two cell right

angle head (T-2DCRA), three cell straight head (T-3DC) and three cell right angle head (T-3DCRA).

The 0.5A bulbs used (2.4v in two cell, 3.6v in three cell models) are high efficiency bulbs giving a high level of light output.

The Ex. construction is also unique, incorporating two separate explosion protected enclosures; a lockable 'Increased Safety' enclosure containing the internal

rotating switch and bulb, and an 'Intrinsically Safe' enclosure for the primary cells.

Each torch comes complete with a lock release pin, wrist lanyard and maintenance instructions. Certification is for any Zinc R20 size type primary cell.

Alkaline Manganese Cells of any description may not be used in this product.

Wolf Intrinsically Safe Primary Cell Torch				
Technical Specification				
Product reference	T-2DC	T-2DCRA	T-3DC	T-3DCRA
Product description	2 cell safety torch straight head	2 cell safety torch r/angle head	3 cell safety torch straight head	3 cell safety torch r/angle head
Code	Ex II 2G EEx e ib IIB T4			
Apparatus standard	EN50014, EN50019, EN50020			
Type of protection	"e" increased safety, "ib" intrinsic safety			
Area of class (gas)	Zones 1 and 2, gas groups IIA and IIB			
Temp. class (gas)	T4			
Ambient temperature	-20°C to +40°C			
Certificate	Baseefa02ATEX0181			
Enclosure	High impact thermoplastic resin			
Lens	Polycarbonate			
Beam type	Variable			
Light source:	Pt. no.	T-203		T-303
	Type	Krypton/Xenon filled filament bulb		
	Volts	2.4V		3.6V
	Watts	1.2W		1.8W
	Output	12 lm		25 lm
	Life	10 hrs		20 hrs
Power source:	Pt. no.	2 x T-20		3 x T-20
	Type	R20 D size zinc primary cells only		
Light duration	up to 5 hours			
Ingress protection	IP 66 to EN60529:1992			
Weight (excl. cells)	200g	225g	215g	240g

Note: All information has been gathered under laboratory conditions, the user must regard the values given as approximate. The Company reserves the right to alter product specifications without prior notice.

WOLF SAFETY LAMP COMPANY

Saxon Road Works, Sheffield S8 0YA, England

Tel: +44 114 255 1051 Fax: +44 114 255 7988

E-mail: info@wolf-safety.co.uk Website: www.wolf-safety.co.uk

MMD/N/4K/2.03



Wolf Safety Lamp Company



WOLF RECHARGEABLE TORCH

ATEX Directive
94/9/EC Compliant



- ATEX approved for explosive gas and dust atmospheres
- High power LED or Halogen bulb versions for outstanding light output
- Compact and lightweight ergonomic torch design
- Two levels of light output give up to six hours duration
- Battery state-of-charge indicator
- Utilises latest battery technology, eliminates 'memory' affect
- Very low maintenance, quick and easy parts replacement
- Mains and vehicle quick charge options.

R-30
4W beam (approx 6°)
Peak luminous intensity at 5m, 340lux

R-50
3W LED beam (approx 6°)
Peak luminous intensity at 5m, 360lux

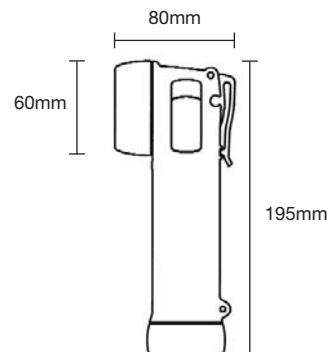
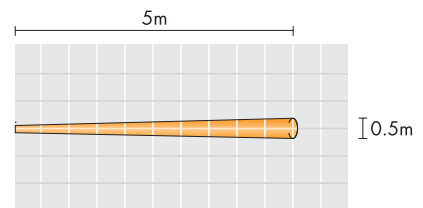

PROVISIONAL

The high-tech ATEX approved Wolf Rechargeable Torch range uses the latest technology to give excellent performance, robustness and reliability in the most extreme conditions.

The Wolf Rechargeable Torch is CE marked to the ATEX Directive, allowing use in zones 1 and 2 potentially explosive gas, vapour, mist and dust atmospheres, where a T4 temperature class permits.

The compact and lightweight Wolf Rechargeable Torch design has a high-grip ergonomic form with easy single handed switching, even with gloved hands. The high strength torch body has proven impact resistance even at sub zero temperatures. The rubber armoured lens ring and end cap give enhanced grip and shock

protection. The shatterproof polycarbonate lens has a scratch and chemical resistant coating. The enclosure is sealed dust tight and protected from water immersion, with a certified IP67 enclosure. The right-angle body arrangement incorporates a replaceable high strength thermoplastic belt clip for hands free use.

Unique optics deliver a piercing beam with outstanding light output from the high power LED or the halogen bulb versions. Duration is over 3 hours; selecting low power doubles this duration. State of battery charge is indicated with a bar of high intensity red LEDs, which go out as battery charge diminishes. Towards the end of discharge, the beam flashes off repeatedly, warning recharging is required. Use of the latest

lithium-ion battery technology improves reliability and eliminates 'memory' affect.

The RC-200 Charger is configured as a torch holder, and will 'quick' charge a torch in 2.5 hours. A major feature is the single-handed, 'snap-in/snatch-out' function, for quick release but secure retention, even with vehicle vibration. The charger is powered from vehicle voltages, but can run from mains voltage when used with the RC-300 mains power supply.

Very low maintenance and quick component replacement are key benefits of this product range. The LED light source is expected to last the product lifetime; the bulb is long life, a spare is supplied in the torch. All models are supplied with wrist straps and clip rings.

Wolf Rechargeable Torch Technical Specification

Product reference		R-30	R-50
Product description		Rechargeable safety torch, right-angle	
		Halogen light source	LED light source
Code		II 2GD EEx e ib IIC T4 IP67 T135°C	II 2GD EEx ib IIC T4 IP67 T135°C
Equipment category		2 GD	
Apparatus standards		EN50014, EN50019, EN50020, EN50281-1-1	
Type of protection		"e" increased safety, "ib" intrinsic safety	
Area of classification (Gases)		Zone 1 and 2, Gas groups IIA, IIB and IIC	
Temp. classification (Gases)		T4	
Area of classification (Dust)		Zones 21 and 22	
Max surface temp. (Dusts)		T135°C	
Ambient temperature		-20°C to +40°C	
Certificate		Baseefa05ATEX0068	Baseefa05ATEX0069
Enclosure		Impact resistant thermoplastic, electrostatic non-hazardous	
Lens		Polycarbonate, impact resistant with hardcoat	
Beam type		Medium Spot	
Light source:	Pt. no.	R-451	Non replaceable
	Type	Halogen filled filament bulb	High power LED
	Volts	6.0V	n/a
	Watts	4W	3W
	Output	54 lm	65 lm
	Life	300 hours	25000 hours
Power source:	Pt. no.	R-271	
	Type	Rechargeable battery, Lithium-Ion	
	Volts	7.4V	
	Capacity	2.2Ah	
Life	Up to 500 recharge cycles		
Light duration	high/low	3.5/6.5 hrs	3.0/5.5 hrs
Ingress protection		IP67 to EN60529: 1992	
Weight (incl. cells)		0.325 kg	0.375 kg
Compatible charger		RC-200 12-24Vdc (e11 compliant) RC-200 + RC-300 110/230Vac	
Recharge time		2.5 hrs	

Note: All information has been gathered under laboratory conditions, the user must regard the values given as approximate. The Company reserves the right to alter product specifications without prior notice.

WOLF SAFETY LAMP COMPANY

Saxon Road Works, Sheffield S8 0YA, England

Tel: +44 114 255 1051 Fax: +44 114 255 7988

E-mail: info@wolf-safety.co.uk Website: www.wolf-safety.co.uk

SL007 issue 01

MMD/PC/04.05/3K



Wolf Safety Lamp Company



WOLFLITE HANDLAMP H-4DCA

ATEX Directive
94/9/EC
Compliant



- CE marked to ATEX Directive
- Explosive gas, vapour and mist certified for zones 1 & 2, up to T4 temperature class
- Dust ignition protected for zones 21 and 22, for dusts with ignition temperatures over 135°C
- Increased light output from halogen bulb
- Alkaline cell approval giving 20 hour duration
- Robust anti-static thermoplastic lamp enclosure
- Ingress protection to IP66
- Lloyd's Register Type Approved
- Supplied with detachable shoulder strap

Wolfite H-4DCA
2.4w spot beam (approx 3.5°)
Peak luminous intensity at 5m **960lux**

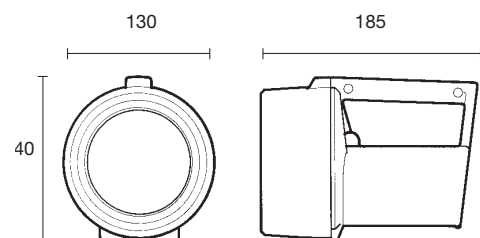
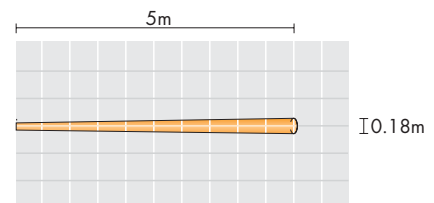

The Wolfite H-4DCA primary cell powered safety handlamp is one of the latest versions of the highly successful, industry standard range of Wolfite Ex handlamps, from The Wolf Safety Lamp Company.

Approved by BASEEFA, the Wolfite H-4DCA has been 'CE' marked in compliance with the 94/9/EC 'Explosive Atmospheres' (ATEX) Directive, for use in a wide range of potentially explosive gases, vapours, mists and dusts.

Conformance to the ATEX directive will reassure the user that the H-4DCA handlamp has been designed and approved to the very latest editions and interpretations of the relevant European standards, that it complies with all 'essential safety requirements', and has been designed with due regard to state-of-the-art technology. ATEX Directive Approval also ensures continuity of supply beyond the year 2003.

Additionally the H-4DCA handlamp has both a Lloyd's and an MCA type approval for use in explosive atmospheres in marine applications.

The lamp is constructed from a new, exceptionally robust and highly durable thermoplastic material, well able to withstand the effects of heavy industrial use. In addition to this, the material is anti-static, preventing the build up of potentially dangerous electrostatic charges. A 6mm thick, toughened, scratch resistant glass lens with rubber seal, together with a second seal fitted at the lens ring and lamp body joint, ensure that

the lamp is protected from ingress of dusts and liquids and can therefore be used in the dustiest and wettest conditions possible.

The outstanding light output from this relatively small and compact handlamp is achieved with the use of a high output, high efficiency halogen bulb, rated at 4.8V 0.5A, focused within a 100mm diameter parabolic reflector. This provides the user with an extremely well defined beam of intense white colour.

The H-4DCA handlamp has been approved for use with alkaline manganese, zinc chloride or zinc carbon primary cells. The use of alkaline manganese cells is recommended because of their significantly greater capacity, delivering a brighter white light for up to 20 hours duration from one set of cells; by comparison, nearly four times the duration of zinc D cells. The H-4DCA is supplied complete with a convenient removable shoulder strap.

Wolf Safety Handlamp <i>Technical Specification</i>	
Product reference	H-4DCA
Product description	Safety handlamp, primary cell powered
Code	Ⓔ II 2 GD EEx e ib IIC T4 IP66 T135°C
Equipment category	2 GD
Apparatus standards	EN50014, EN50019, EN50020, EN50281-1-1
Type of protection	"e" increased safety, "ib" intrinsic safety
Area of classification (gases)	Zones 1 and 2, Gas Groups IIA, IIB and IIC
Temp. classification (gases)	T4
Area of classification (dusts)	Zones 21 and 22
Max. surface temp. (dusts)	135°C
Ambient temperature	-20°C to +40°C
Certificate	BAS00ATEX2203
Enclosure	Impact resistant thermoplastic, electrostatic non-hazardous
Lens	Toughened glass (6mm)
Beam type	Spot
Light source:	H-141 only
Pt. no.	
Type	Halogen filled filament bulb
Volts	4.8V
Watts (Amps)	2.4W (0.5A)
Output	37 lm (at nominal voltage)
Life	20 hrs (at nominal voltage)
Power source:	4 x H-20 (LR20)
Pt. no.	
Type	LR20/R20 primary cells, to IEC 60086
Volts	4 x 1.5V
Light duration	Up to 20 hours
Ingress protection	IP66 to EN60529 : 1992
Weight (incl. cells)	1.45kg

Note: All information has been gathered under laboratory conditions, the user must regard the values given as approximate. The Company reserves the right to alter product specifications without prior notice.

WOLF SAFETY LAMP COMPANY

Saxon Road Works, Sheffield S8 0YA, England

Tel: +44 114 255 1051 Fax: +44 114 255 7988

E-mail: info@wolf-safety.co.uk Website: www.wolf-safety.co.uk

MMD/N/4.03/4.5K



Wolf Safety Lamp Company



WOLFLITE HANDLAMP H-251A

ATEX Directive
94/9/EC
Compliant



- CE marked to ATEX Directive
- Explosive gas, vapour and mist certified for zones 1 & 2, up to T4 temperature class
- Dust ignition protected for zones 21 and 22, for dusts with ignition temperatures over 135°C
- Electronic current limited battery with power fail operation and deep discharge protection
- Enhanced light output from halogen bulb
- Robust anti-static thermoplastic lamp enclosure
- Ingress Protection to IP66
- For use with Wolf C-251HV/LV chargers
- Lloyd's Register Type Approved
- Supplied with detachable shoulder strap

WolfLite H-251A
2.8w spot beam (approx 4°)
Peak luminous intensity at 5m 700lux

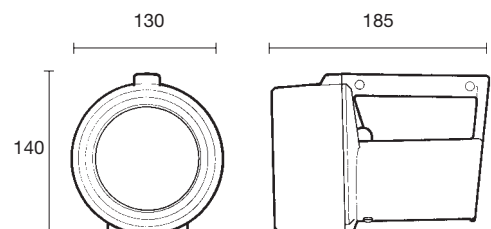
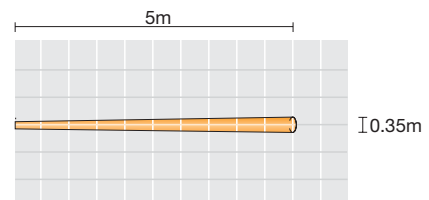

The H-251A Wolfrite is ideal for use as a general purpose safety lamp for inspection and work tasks in explosive atmospheres. Rechargeable battery operation offers a convenient and cost-effective solution for Ex applications where a handlamp is frequently required for long periods.

CE marking of the H-251A Wolfrite is in compliance with the 94/9/EC 'Explosive Atmospheres' (ATEX) Directive and the EMC Directive. BASEEFA approval is to the very latest European 'EN' standards for use in potentially explosive atmospheres. The H-251A also has both a Lloyd's and an MCA Type Approval for use in potentially explosive atmospheres in marine applications.

The H-251A Wolfrite Handlamp offers the same extreme robustness and reliability for use in harsh environments found with all Wolfrite Handlamps. The scratch and impact resistant lens is made from 6mm toughened glass. The handlamp body and lens ring is moulded in a highly resilient thermoplastic material able to withstand the drop and impact expected from heavy industrial use, even at sub-zero temperatures. Additionally the material is electrostatic non-hazardous, ensuring there is no risk of a dangerous build up of static charges. The lamp enclosure is sealed to IP66, preventing the ingress of dust and sealing against water in all conditions except submersion.

The outstanding light output is achieved with the use of a high output, high efficiency long life halogen bulb, focused within a 100mm diameter parabolic reflector giving the user an extremely well defined beam of intense white light.

The battery pack, recharged internally within the H-251A Handlamp, uses the same highly reliable sealed lead acid system as all rechargeable Wolfrite Handlamps, but is enhanced with electronic protection and controls. The battery is rendered intrinsically safe by the use of a fast switching short-circuit protection circuit. A low voltage cut-off feature automatically switches the lamp off when all useful battery capacity has been used, protecting the battery

from damage through deep discharge. Power-failure mode allows the handlamp to be used as an escape light, automatically illuminating if power to the charger is interrupted.

The H-251A is recharged in the standard Wolfrite Lamp chargers, the C-251HV mains charger and the C-251LV vehicle charger.

The H-251A is supplied with a convenient removable shoulder strap.

Wolf Safety Handlamp		
Technical Specification		
Product reference	H-251A	
Product description	Rechargeable safety handlamp	
Code	Ⓔ II 2 GD EEx e ib IIC T4 IP66 T135°C	
Equipment category	2 GD	
Apparatus standards	EN50014, EN50019, EN50020, EN50281-1-1	
Type of protection	"e" increased safety, "ib" intrinsic safety	
Area of classification (Gases)	Zones 1 and 2, Gas Groups IIA, IIB and IIC	
Temp. classification (Gases)	T4	
Area of classification (Dusts)	Zones 21 and 22	
Max. surface temp. (Dusts)	135°C	
Ambient temperature	-20°C to +40°C	
Certificate	BAS00ATEX2176	
Enclosure	Impact resistant thermoplastic, electrostatic non-hazardous	
Lens	Toughened glass (6mm)	
Beam type	Spot	
Light source:	Pt. no.	H-69
	Type	Halogen filled filament bulb
	Volts	3.75V
	Watts	2.8W
	Output	39 lm (at 3.75V)
	Life	100 hrs
Power source:	Pt. no.	H-66
	Type	Rechargeable battery, sealed lead acid
	Volts	4V
	Capacity	5Ah
	Life	Up to 500 recharge cycles
Light duration	Up to 7 hours	
Ingress protection	IP66 to EN60529 : 1992	
Weight (incl. cells)	1.75kg	
Compatible charger	C-251 HV or C-251 LV	

Note: All information has been gathered under laboratory conditions, the user must regard the values given as approximate. The Company reserves the right to alter product specifications without prior notice.

WOLF SAFETY LAMP COMPANY

Saxon Road Works, Sheffield S8 0YA, England

Tel: +44 114 255 1051 Fax: +44 114 255 7988

E-mail: info@wolf-safety.co.uk Website: www.wolf-safety.co.uk

SL002 issue 01

MMD/WK/10.04/3K



Wolf Safety Lamp Company



WOLFLITE HANDLAMP H-251 Mk1/Mk2



- Market Leading Rechargeable Handlamp
- Long-life, high output Krypton Bulb
- Design Council Awarded
- Sealed Lead Acid Reliability
- User and Maintenance Friendly
- Reliable Efficient Chargers
- Lloyd's Register Type Approved



WolfLite H-251
3.6w spot beam (approx 3°)
Peak luminous intensity at 5m **900lux**

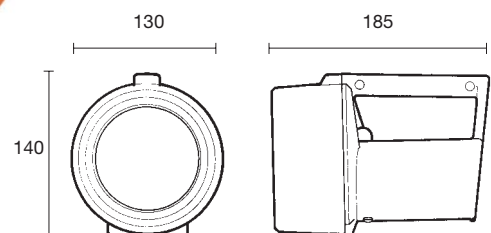
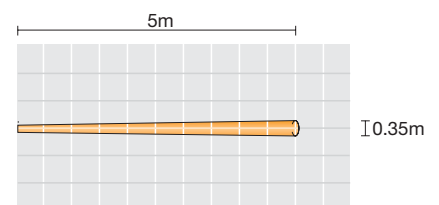

The Wolflite H-251 is a rechargeable Handlamp approved to European and BASEEFA standards and suitable for use in hazardous zones 1 and 2. Since its launch in 1980 the Wolflite has found a place as the market leader in hazardous area portable lighting equipment. Applications include the Petrochemical and Offshore industries, Fire-fighting, Gas and Water distribution, in short wherever a potentially explosive atmosphere may occur.

The Wolflite is constructed in a highly durable polymer, designed to withstand the effects of heavy industrial use. The glass lens is scratch and scuff resistant and will not discolour when in contact with chemicals. The entire product has been 'drop' tested for damage and both the outer and inner components proved equally highly resilient.

Many unique design features are incorporated in the H-251 Handlamp, including; an interlock mechanism preventing internal access when the lamp is in use, short circuit protection via a ceramic fuse and a magnetically operated, hermetically sealed Reed Switch to avoid open internal sparking.

The rechargeable battery pack is made up of two sealed lead acid cells assembled into a robust casing. This battery pack has a recharge/discharge life of approximately 500 cycles.

Available in two versions, the H-251 Mk1 has a removable battery pack

and remote battery charging unit so that, if the user has two or more battery packs, the lamp can always be available for use. The H-251 Mk2 has charging contacts on the base of the lamp to enable battery charging 'in situ' using the lamp charger. The H-251 Mk2 Lamp chargers are available for mains (120/230v) input or low voltage (12-32v) input for use in vehicles. All chargers have Light Emitting Diodes which indicate state of charge, a rating plate on the charger explains the sequence of this.

The Wolflite H-251 Handlamps conform with the DOT Class I 'Safety Lamp' specification, Regulation 17 of the SOLAS protocol and have been issued with a Lloyds Register of Shipping Type Approval Certificate.

The Wolflite H-251 is supplied complete with battery pack, lock key and shoulder lanyard, together with maintenance instructions giving comprehensive details of spares available and guidance for installation.

Wolflite H-251 Safety Handlamps		
<i>Technical Specification</i>		
Product reference	H-251 Mk1	H-251 Mk2
Product description	Rechargeable safety handlamp, battery charged externally	Rechargeable safety handlamp, battery charged internally
Code	EEx e s II T3	
Apparatus standard	EN50 014, EN50 019, SFA 3009:1972	
Type of protection	"e" increased safety, "s" special protection	
Area of classification	Zones 1 and 2, gas groups IIA, IIB and IIC	
Temp. classification	T3	
Ambient temperature	-20°C to +40°C	
Certification	BASEEFA Certificate No. Ex 81142	
Enclosure	High impact polymer	
Lens	Toughened glass (6mm)	
Beam type	Spot	
Light source:	Pt. no.	H-26
	Type	Krypton filled filament bulb
	Volts	3.6v
	Watts	3.6w
	Output	80 lm (at 4.1v)
Power source:	Life	100hrs
	Pt. no.	H-16E
	Type	Rechargeable battery, sealed lead acid
	Volts	4v
	Capacity	5Ah
Life	up to 500 recharge cycles	
Light duration	4-5 hours	
Ingress protection	IP 66	IP 54
Weight	1.5kg	
Compatible charger	C-251	C-251 HV or C-251 LV

Note: All information has been gathered under laboratory conditions, the user must regard the values given as approximate. The Company reserves the right to alter product specifications without prior notice.

WOLF SAFETY LAMP COMPANY

Saxon Road Works, Sheffield S8 0YA, England

Tel: +44 114 255 1051 Fax: +44 114 255 7988

E-mail: info@wolf-safety.co.uk Website: www.wolf-safety.co.uk

MMD/N/12.03/2K





WOLF 'ZONE 0' HEADTORCH HT-200

**ATEX Directive
94/9/EC
Compliant**



- Certified to ATEX Directive
- IECEx Scheme Certified
- Explosive gas, vapour and mist certified for zones 0,1 & 2
- Up to T4 temperature class
- Seven 'Everlasting' High intensity LEDs
- Push button switchable three, five or seven LEDs
- Long 50 hour duration at full brightness
- Robust anti-static thermoplastic enclosure
- Fitted with fabric head band
- Supplied with Rubber helmet band for hard hat use

Wolf 'Zone 0' Headtorch HT-200
Seven high output LEDs (approx 28°)
Peak luminous intensity at 1m 114 lux, at 2.5m 19 lux

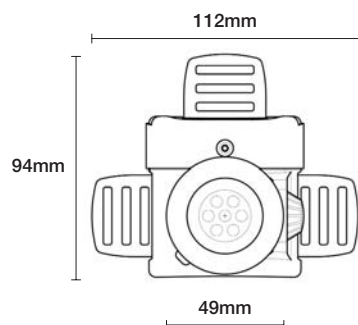
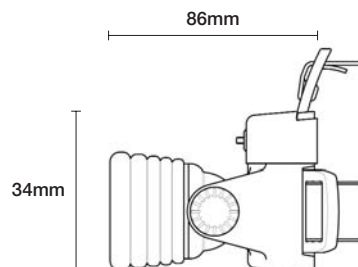
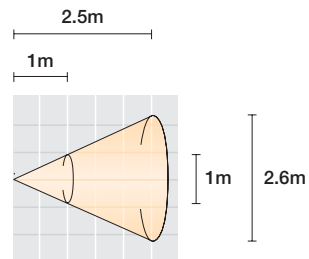

IECEx

The Wolf 'Zone 0' Headtorch HT-200 is a primary cell powered head lamp with LED light source. It is ATEX approved for safe use in Zone 0 Hazardous Areas and is ideal for applications where hands free lighting is essential, particularly where access is difficult, requiring climbing or crawling.

The HT-200 Headtorch has been Certified by Baseefa for use in explosive atmospheres. It is CE marked in compliance with the 94/9/EC (ATEX Equipment) Directive, for use in shore-based hazardous area activities within the EU. In addition it has an IECEx Scheme certificate for use in other countries throughout the world. The approval code allows the Headtorch to be used in zones 0, 1 & 2 hazardous areas, in all group II (industrial) gas apparatus groups, for potentially explosive gases, vapours and mists up to T4 or T3

temperature class, dependant on cell type used.

The Wolf 'Zone 0' Headtorch has a compact, lightweight design and is constructed from a robust and highly durable thermoplastic material, which is inherently anti-static, minimising the risk of ignition from static charges. The lens is treated with a scratch resistant anti-static coating and the lens module is fitted with a rubber shroud, protecting the product from impact damage, ensuring suitability in industrial applications. The HT-200 has a metal locking clasp, securing the headtorch battery enclosure to prevent accidental opening in the hazardous area, but designed for quick removal allowing easy cell replacement.

Seven high intensity, everlasting, white LEDs give 50 hours duration at full brightness from one set of

three AA alkaline primary cells (up to 240 hours with reduced output). The use of primary cells makes the product a more economical solution for personal lighting requirements in many applications arising in Hazardous Area confined spaces. Three switching levels, selected using the push button integral to the rubber shroud, ensure a wide range of options for duration and brightness. The lamp head can be pivoted, allowing for easy control of the light output direction up or down.

The HT-200 is designed to give the user effective hands free lighting. It is supplied fitted with a fabric head band and padded lamp backing, allowing the headtorch to be comfortably worn directly on the head for extended periods. Alternatively, a rubber head band is supplied and can be fitted for effective use on hardhats.

Wolf 'Zone 0' Headtorch		
<i>Technical Specification</i>		
Product reference	HT-200	
Product description	Safety headtorch, primary cell powered	
Code	II 1 G EEx ia IIC T4/T3 Ex ia IIC T4/T3	
Apparatus standards	EN50014, EN50020, IEC60079-0, IEC60079-11	
Type of protection	"ia" intrinsic safety	
Area of classification (Gases)	Zones 0, 1 and 2, Gas groups IIA, IIB, IIC	
Temp. classification (Gases)	T4/T3	
Ambient temperature	-20°C to +40°C	
Certificate	Baseefa04 ATEX0398 IEC Ex Bas 04.0053	
Enclosure	Thermoplastic, anti-static	
Lens	Antistatic coated polycarbonate	
Beam type	Wide angle	
Light source:	Type	Seven white high intensity LEDs
	Life	100,000 hours (typical)
Power source:	Pt. no.	3 x HT-210 (LR6)
	Type	LR6/R6 primary cells, to IEC 60086 (T4/T3 see instructions)
	Volts	3 x 1.5v
Light duration	Up to 240 hours (50 hours at full brightness)	
Ingress protection	IP54	
Weight (incl. cells)	215g	

Note: All information has been gathered under laboratory conditions, the user must regard the values given as approximate. The Company reserves the right to alter product specifications without prior notice.

WOLF SAFETY LAMP COMPANY

Saxon Road Works, Sheffield S8 0YA, England

Tel: +44 114 255 1051 Fax: +44 114 255 7988

E-mail: info@wolf-safety.co.uk Website: www.wolf-safety.co.uk

SL006 issue 01

MMD/PC/04.05/3K





DUO ATEX HEADLAMP

ATEX Directive
94/9/EC
Compliant



- Completely hands free
- For head or hardhat use
- Pivoting head unit for accurate beam positioning
- Selectable LED or incandescent light source
- CE marked to ATEX Directive
- Explosive gas, vapour and mist certified for zones 1 & 2
- Rechargeable, supplied with "quick" battery charger
- Robust, ergonomic design
- Up to 7 hour battery duration when using bulb

ATEX Duo HT-01

2W variable beam

Peak luminous intensity for spot beam (approx 4.5°) at 5m, 31lux

Peak luminous intensity for wide beam (approx 13.5°) at 5m, 14lux

0.5w LED BEAM

Peak luminous intensity (approx 27°) at 2.5m, 6.5lux

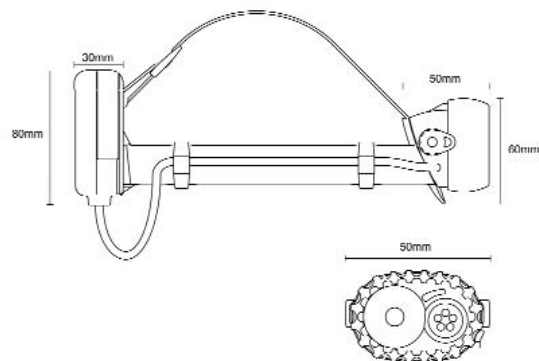
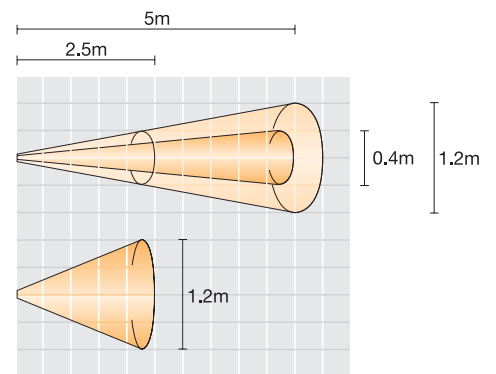

Quick Charge
Long Duration

The Duo ATEX is a rechargeable headband lamp approved for safe use in potentially explosive gas, vapour and mist atmospheres. It is the ideal lighting solution for workers in confined spaces and hazardous areas, needing a 'hands free' lamp, which will direct a beam of light wherever they look.

CE marking in compliance with the 94/9/EC explosive atmospheres 'ATEX' Directive confirms that the Duo ATEX is compliant with the latest European legislation, and is safe for use in zone 1 and 2 hazardous areas, where the T3 temperature class permits.

The Duo ATEX comprises of a head unit and a battery box joined by a cable, and mounted on an

elastic headband. Both head unit and battery box are sealed 'water resistant' and are constructed from high quality impact resistant plastic materials. The lens is shatterproof polycarbonate. The headband is adjustable, for use on a head or a hardhat. Helmet clips are available for hardhat use, as additional items, to secure the elasticated straps in place.

The Duo ATEX incorporates two light sources, selected using an externally mounted switch with lock feature to prevent accidental switching. The 2 watt filament bulb has a 'zoom' function, allowing beam adjustment from narrow spot to wide angle flood and gives a duration of up to 7 hours.

Alternatively, the bright, white LED light source offers energy efficient close-up illumination for up to 24 hours. The LEDs will run for up to 160 hours, but at a reduced light output. The head unit will pivot up or down for accurate beam positioning. A spare bulb is supplied, fitted inside the head unit.

The rechargeable battery pack is short-circuit protected to intrinsically safe levels and is safe to be removed and replaced in the hazardous area. The Duo ATEX is supplied with a mains "quick" charger, fully charging a completely discharged battery pack in 4 hours. Alternatively a vehicle charger is available to charge the battery from a 12v vehicle supply.

Duo ATEX Headlamp <i>Technical Specification</i>		
Product reference	HT-01	
Product description	Rechargeable safety headband lamp E61L5UK	
Code	II 2 G EEx e ia IIC T3	
Equipment category	2 G	
Apparatus standards	EN50014, EN50019, EN50020	
Type of protection	"e" increased safety, "ib" intrinsic safety	
Area of classification (Gases)	Zone 1 and 2, Gas groups IIA, IIB, IIC	
Temp. classification (Gases)	T3	
Ambient temperature	-5°C to +40°C	
Certificate	INERIS02ATEX0056	
Enclosure	High impact thermoplastic	
Lens	Polycarbonate	
Beam type	Switchable from variable bulb to fixed LED	
Light source:	Pt. no.	HT-02
	Type	Main vacuum bulb
	Volts	6V
	Watts	2W
Power source:	Pt. no.	HT-08
	Type	Ni MH
	Volts	4.8V
	Capacity	2.7Ah
	Life	500 cycles
Light duration	Up to 7 hrs	Up to 24 hrs
Ingress protection	IP54	
Weight (incl. battery)	0.325 kg	
Charger reference	Supplied with HT-01	HT-20
Product description	E65200 2UK, 230V Mains charger	E65300, 12V Vehicle charger
Insulation class	II	III
Enclosure	Plastic	Plastic
Input voltage	230V	12V
Recharge time	4 hrs	14 hrs
Ingress protection	IP20	IP20

Note: All information has been gathered under laboratory conditions, the user must regard the values given as approximate. The Company reserves the right to alter product specifications without prior notice.

WOLF SAFETY LAMP COMPANY

Saxon Road Works, Sheffield S8 0YA, England

Tel: +44 114 255 1051 Fax: +44 114 255 7988

E-mail: info@wolf-safety.co.uk Website: www.wolf-safety.co.uk

SL003 issue 01

MMD/WK/10.04/3K



Wolf Safety Lamp Company



WOLF Ex GLS LEADLAMP



- **ATEX approval for use in zones 1 & 2 explosive atmospheres**
- **Uses standard 60 watt GLS rough service ES lamps**
- **Robust construction with rubber handle and impact ring**
- **Toughened glass cover with steel cage**
- **Cast iron locking ring**
- **Convenient integral hanging hook**
- **Ingress protection to IP54**
- **Can be supplied, fitted with cable**

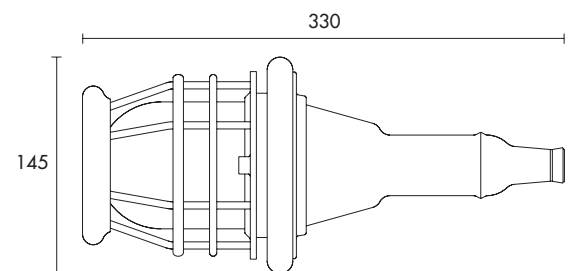

The Wolf Ex GLS Leadlamp is a cost effective explosionproof lamp for use in many hazardous area applications. It is ideal for localised inspection and maintenance operations over extended periods.

The Ex GLS Leadlamp is ATEX compliant and approved for use in zones 1 and 2 hazardous areas, for IIA gases where a T3 temperature class permits.

This gives the lamp the versatility of use in many potentially explosive atmospheres including methane, petroleum and propane.

The lamp for the Ex GLS Leadlamp is a standard 230V 60W GLS rough service ES. This gives a good ambient light, ideal for plant inspection and maintenance duties.

The Ex GLS Leadlamp light source is protected by a toughened glass dome, which is able to withstand changes in temperature, preventing the risk of failure from thermal shock. A steel cage guard with cast iron locking ring minimises the risk of direct impact damage, further protecting the glass. The guard and ring are plated to prevent

corrosion. Finally, the resilient rubber construction incorporates two rubber rings on both the top and bottom of the steel guard. These are ideal for absorbing the general impact expected from industrial use.

User benefits in operating the Leadlamp include a rubber handle for enhanced grip, a convenient

retractable hook incorporated in the steel guard by which the handlamp can be hung, and a weight of just over 2Kg.

The Ex GLS Leadlamp is sealed to IP54, protecting against the ingress of dust and rendering the enclosure weatherproof. It is supplied fitted with 10 metres of cable, but is supplied without a lamp.

Wolf Ex GLS Leadlamp Technical Specification		
Product reference		LL-01E
Product description		Explosionproof handheld leadlamp 439/GK
Code		II 2 G EEx d e IIA T3
Equipment category		2 G
Apparatus standards		EN50014, EN50018, EN50019
Type of protection		'd' flameproof, 'e' increased safety
Area of classification (gases)		Zones 1 and 2, gas group IIA
Temp. classification (gases)		T3
Ambient temperature		- 20°C to +40°C
Certificate		IBExU03ATEX1018X
Enclosure		Rubber with steel guard and cast iron lock ring
Lens		Moulded glass, toughened and resistant to thermal shock
Light source:	Pt. no.	LL-436
	Type	GLS rough service ES lamp
	Volts	230V
	Watts	60W
	Beam	360°
Power source:	Insulation	Class II
	Voltage	230Vac/dc
Ingress protection		IP54 minimum
Weight		2.1 kg (excluding cable)

Note: All information has been gathered under laboratory conditions, the user must regard the values given as approximate. The Company reserves the right to alter product specifications without prior notice.

WOLF SAFETY LAMP COMPANY

Saxon Road Works, Sheffield S8 0YA, England

Tel: +44 114 255 1051 Fax: +44 114 255 7988

E-mail: info@wolf-safety.co.uk Website: www.wolf-safety.co.uk

MMD/N/.8.02/2K



Wolf Safety Lamp Company



WOLF FLAMEPROOF LEADLAMP

ATEX Directive
94/9/EC
Compliant



- Complies with ATEX Directive 94/9/EC
- High output halogen light, up to 70 watts
- Lightweight alloy construction for single handed portability
- Zone 1 & 2, Gas group IIC T3/T4 certified
- Designed for quick and easy re-lamping and maintenance
- 12, 24 or 42 Volts models available
- Integral operation switch
- Oil resistant rubber guard for drop and impact protection
- Ideal for cleaning, grit blasting and painting operations

Wolf Flameproof Leadlamp LL-12
55w with flood beam (approx 100°)
Peak Luminous Intensity at 5m 180 lux

Wolf Flameproof Leadlamp LL-24
70w with flood beam (approx 100°)
Peak Luminous Intensity at 5m 180 lux

Wolf Flameproof Leadlamp LL-42
65w with flood beam (approx 100°)
Peak Luminous Intensity at 5m 180 lux

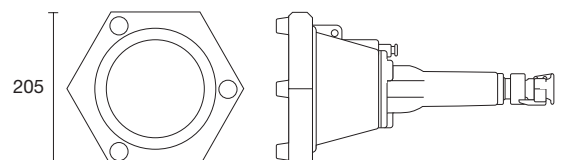
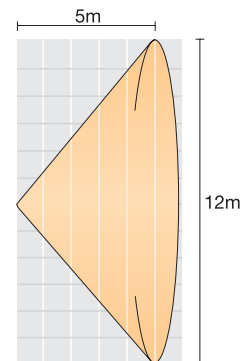

The Wolf Flameproof Leadlamp is a lightweight portable Floodlight for use in potentially explosive atmospheres. It complies with the ATEX Directive (94/9/EC) and has been certified to the European EN50014 series of standards by the German test house DMT, for use in zones 1 and 2, group II (surface industry) hazardous area applications. It is approved for safe use in all potentially explosive gas, vapour and mist atmospheres to gas group IIC, where the T3/T4 temperature class permits.

Three different versions of the Leadlamp are available, with the option of powering from a 12, 24 or 42 Volt supply. Bulb ratings vary from 55 to 70 Watts, all versions offering unparalleled light output over an extremely wide 100° solid cone of light, ideal for confined space operations.

The Flameproof Leadlamp has a die cast aluminium alloy construction making the product lightweight and portable, ideal for carrying during extended shifts in offshore and onshore cleaning operations. The Leadlamp is constructed as a flameproof enclosure, containing the halogen bulb, switch and connecting wires. A flameproof threaded joint allows internal access, making bulb replacement and other minor maintenance a quick and simple

operation. A large hexagonal rubber moulded guard is fitted to the outside of the head of the lamp, ensuring the glass lens and the flameproof threaded joint are both protected from drop or impact damage. The handle is moulded in tough high impact plastic and fitted with a cable clamp, and provides protection for the increased safety clamped cable terminals.

Flameproof leadlamps are used extensively in many explosive atmosphere applications, particularly in cleaning, grit

blasting and painting operations in tanks, silos and pipelines.

Cables and plugs of the appropriate rating and duty must be used. In explosive atmospheres 'Ex' component certified plugs, sockets and suitable fusing are required.

A leather carrying strap is supplied with each Lamp unit.

Wolf Flameproof Leadlamp Technical Specification				
Product reference		LL-12	LL-24	LL-42
Product designation	KHLE 70 EN			
Product description	High power halogen floodlight leadlamp			
Code	II 2 G EEx d e IIC T3/T4			
Equipment category	2G			
Apparatus standard	EN50014, EN50018, EN50019			
Type of protection	'd' flameproof, 'e' increased safety			
Area of classification (gases)	Zones 1 and 2, gas groups IIA, IIB and IIC			
Temp. classification (gases)	T4	T3	T3	
Ambient temperature	-20°C to +40°C			
Certification	DMT03ATEXE279			
Enclosure	Light alloy, high impact plastic, oil resistant rubber			
Lens	Toughened glass			
Light source:	Pt. no.	LL-230	LL-232	LL-234
	Type	Halogen filament lamp		
	Volts	12V	24V	42V
	Watts	55W	70W	65W
	Beam	100° wide angle flood		
	Life	Up to 1000 hrs		
Power source:	Insulation	Class III		
	Voltage	12 Vac/dc	24 Vac/dc	42 Vac/dc
Ingress Protection	IP54 minimum			
Weight	2.5 Kg (excluding cable)			

Note: All information has been gathered under laboratory conditions, the user must regard the values given as approximate. The Company reserves the right to alter product specifications without prior notice.

WOLF SAFETY LAMP COMPANY

Saxon Road Works, Sheffield S8 0YA, England

Tel: +44 114 255 1051 Fax: +44 114 255 7988

E-mail: info@wolf-safety.co.uk Website: www.wolf-safety.co.uk

SL004 issue 01

MMD/WK/10.04/3K





WOLF ATEX TURBOLITE

**ATEX Directive
94/9/EC
Compliant**



- CE marked to ATEX Directive, for use in zones 1 and 2 Hazardous Areas
- Aluminium super-lightweight construction
- 250 watt Halogen light output
- Safe compressed air power source
- Re-designed for greater reliability
- Fitted with stainless steel exhaust silencer
- Dust ignition protected for zones 21 and 22 using remote exhaust
- Group I Mining approval with alternative brass construction
- US Factory Mutual dual marking approval

A-TL45A/B



A-TL44A/B

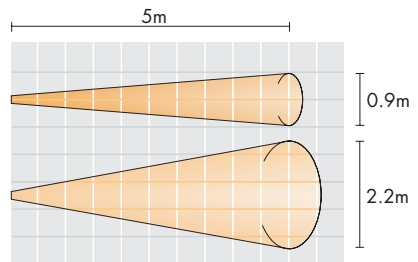
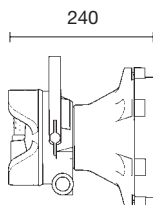
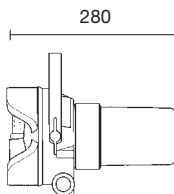

Wolf Turbolite A-TL44A/B
250w with ball glass for all round illumination
Peak luminous intensity at 2.5m radius **70lux**

Wolf Turbolite A-TL45A/B
250w with polished reflector spot beam (approx 10°)
Peak luminous intensity at 5m **2000lux**

Wolf Turbolite A-TL45A/B
250w with matt reflector flood beam (approx 25°)
Peak luminous intensity at 5m **950lux**

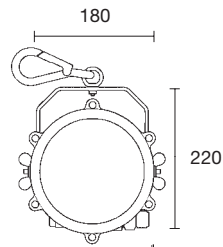
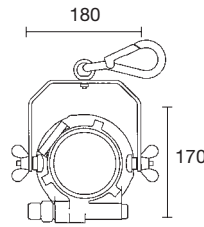

**Aluminium
super-lightweight
construction**

Wolf ATEX Turbolite lamps are high power compressed air driven units for use in potentially explosive atmospheres. With a safety record of 75 years, Wolf Airlamps are one of the safest high power portable lamps for hazardous areas.

The new generation ATEX Turbolite meets EN 1127 – 'Explosion prevention and protection', for Europe; and in the USA, FM Class 3600 'Electrical Equipment for use in Hazardous (Classified) Locations'.

Used extensively in the petrochemical, oil and marine industries, Wolf Airlamps provide illumination in many applications including shotblasting, cleaning and coating of storage tanks and vessels, and for pipeline and structural engineering activities, offering a safer alternative to mains and low voltage lighting where explosive atmospheres present a serious risk to the workforce.

The standard range consists of two models, both produced in

high strength aluminium alloy. The **A-TL44A** 'Bay Light' version provides a high level of all-round general illumination. The **A-TL45A** 'Floodlight' version has a reflector head with a matt reflector giving a wide-angle diffused beam.

The '**A**' suffix denotes ATEX lightweight aluminium models, **reducing Turbolite weight to approximately half** that of the brass airlamps. Alternative '**B**' suffix models A-TL44B and A-TL45B are also ATEX but with brass housings, usable in gassy mines. All lamps are nickel plated to protect against corrosion and are supplied with a bridle and safety hook fitted.

The Turbolite is powered, purged, pressurised and cooled by compressed air controlled by an integral regulator, which passes through the lamp head and drives the turbine wheel by means of three nozzle plates. The turbine drives a magnet rotor within windings,

generating the 24 Volt ac electrical supply which powers the 250 Watt halogen bulb.

Major improvements over the existing models, include sealed bearings, a refined regulator, greater use of stainless steel components, a bulb-life enhancing device and a new silencer, incorporating a particle trap.

Special conditions of certification for all Turbolites are that clean, dry compressed air and anti-static air hose are used to operate the lamp, minimising contamination inside the lamp and dangerous accumulation of static electricity. When used in potentially explosive dust atmospheres a 'remote exhaust' must be used, exhausting air to the safe area.

A full range of accessories is available, including anti-static hose, filters, filter stands, airlamp tripods and setting and testing devices.

Wolf ATEX Turbolite				
Technical Specification				
Product reference	A-TL44A		A-TL44B	
Product description	Safety bay light, compressed air powered		Safety flood light, compressed air powered	
Code	ATEX Industrial	Ⓔ II 2 GD II T4 (Tamb = 55°C) T135°C		
	ATEX Mining	—	Ⓔ I M2	—
	FM	Class 1 Div 1 Groups A, B, C, D. T4 Ta = 55°C		
Equipment category	2 GD			
	—	M2	—	M2
Apparatus standards	EN1127:1998			
Type of protection	Technical File			
Area of classification (gases)	Zones 1 and 2, Gas Groups IIA, IIB, IIC			
Temp. classification (gases)	T4			
Area of classification (dusts)	Zones 21 and 22			
Max surface temp. (dusts)	T135°C			
Ambient temperature	-20°C to +40°C			
Certificate	SIRA02ATEX5099X			
Enclosure	Aluminium	Brass		Aluminium
Lens	Ball glass/plastic dome		Toughened glass (15mm)	
Beam type	All-around 360°C illumination		Flood (as standard) or spot to order	
Light source:	Pt. no.	A-129 (as standard)/ A-159 (alternative)		
	Type	Halogen filled filament bulb		
	Volts	24v		
	Watts	250w		
	Output	6000 lm/9000 lm		
	Life	2000 hrs/200 hrs		
Power source:	Type	Compressed air driven turbo-alternator		
	Air pressure	5.0-8.0 bar		
	Consumption	0.75m ³ /min		
Ingress protection	Once pressurised, may be used underwater			
Weight	5.5kg	9.4kg	7.1kg	13.5kg
Special certification conditions	A clean dry air supply must be used Supply hose must be anti-static Lamps used in explosive dust atmospheres must have a remote exhaust hose to the safe area			

Note: All information has been gathered under laboratory conditions, the user must regard the values given as approximate. The Company reserves the right to alter product specifications without prior notice.

WOLF SAFETY LAMP COMPANY

Saxon Road Works, Sheffield S8 0YA, England

Tel: +44 114 255 1051 Fax: +44 114 255 7988

E-mail: info@wolf-safety.co.uk Website: www.wolf-safety.co.uk

SL001 issue 01

MMD/WK/10.04/3K



Wolf Safety Lamp Company



WOLF ATEX LITETRACKER & BIKELITE

ATEX Directive
94/9/EC
Compliant



- Multi-functional, selectable torch-flash-strobe output
- ATEX approved for use in explosive atmospheres
- Can be used as a Zone 0 mini torch
- Up to 10hrs duration in torch mode
- Enhanced user conspicuity in dark conditions
- High intensity LED light source
- High strength polycarbonate case
- Small and lightweight
- IP67 watertight and dust tight



LiteTracker LT-131 and Bikelite LT-131B
LED medium angle beam (approx 15°)
Peak luminous intensity at 1m 14 lux, at 2.5m 2 lux

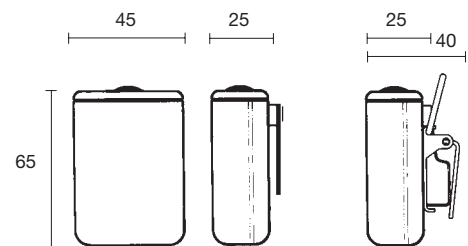
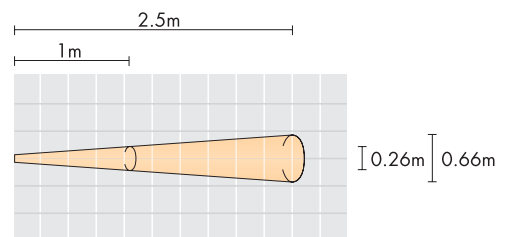

The LT-2000 series LiteTracker, and LiteTracker Bikelite are the latest developments from the LiteTracker range for indication and illumination in explosive atmospheres.

The LiteTracker is ideal as a personal indicator to identify the position of workers in confined spaces. Alternatively, it can be switched to torch mode and used as a mini flashlight for close inspection work.

The LiteTracker Bikelite is a development for bicycle users on chemical sites. It can be fitted to a bicycle frame and will highlight a cyclists' position, maximising visibility in low light and night time conditions.

All LiteTracker versions are compliant with the 94/9/EC ATEX Directive for use in potentially explosive atmospheres, and can be used in Zones 0, 1 & 2 hazardous areas, within T4 temperature classification.

All models utilise a high intensity LED light source that can be seen at night time from distances of up to one kilometre, and will last the life of the product. The LiteTracker is available in five different colours, the main application being for the white LT-131 model, for use as a Zone 0 mini torch. The LiteTracker Bikelite is available in white (front) and red (rear).

Low running cost is guaranteed with the use of two standard alkaline LR03 (AAA) batteries, delivering an

8 – 10 hour duration on torch mode, up to 50 hour on flash sequence, or a 30 hour strobe light output. Different outputs (torch-flash-strobe) can be selected using the top mounted push-button switch.

The LiteTracker has a high strength polycarbonate casing with a metal grip clip and D ring fitting for attachment to webbing or clothing. The LiteTracker Bikelite is supplied with a stainless steel bracket attached to the polycarbonate case, and a bicycle frame bracket to which the Bikelite can be easily fitted, or removed for storage in a pocket.

Weighing only 100g, including cells and sealed to IP67, all LiteTracker versions will be unaffected by excessively wet conditions.

Wolf LiteTracker & Bikelite – LT2000 series Technical Specification

Product reference	LT-131	LT-133	LT-135	LT-137	LT-139	LT-131B	LT-135B
Product description	Personal "Ex" mini torch/strobe light					"Ex" Bikelite	
Code	II 1 G EEx e ib IIC T4						
Equipment category	1G						
Apparatus standards	EN50014, EN50020						
Type of protection	Intrinsic safety						
Area of classification (Gases)	Zone 0, 1 and 2, gas groups IIA, IIB and IIC						
Temp. classification	T4						
Ambient temperature	-20 °C to +40°C						
Certificate	BAS99ATEX1017						
Enclosure	Polycarbonate						
Lens	Internal prismatic light multiplier/diffuser						
Light source:	Type	Solid state LED					
	Colour	white	amber	red	blue	green	white
Power source:	Pt. no.	2 x LT-401					
	Type	AAA (LR03 recommended)					
	Volts	2 x 1.5v					
Light duration:	Glow	8-10 hrs					
	Flash	Up to 50 hrs					
	Strobe	Up to 30 hrs					
Ingress protection	IP67 to EN60529:1992						
Weight (incl. cells)	100g						

Note: this product is intended to enhance the visibility of bicycle users on private roads. Users should establish suitability for use on public roads with regard to legal requirements, etc.

All information has been gathered under laboratory conditions, the user must regard the values given as approximate. The Company reserves the right to alter product specifications without prior notice.

WOLF SAFETY LAMP COMPANY

Saxon Road Works, Sheffield S8 0YA, England

Tel: +44 114 255 1051 Fax: +44 114 255 7988

E-mail: info@wolf-safety.co.uk Website: www.wolf-safety.co.uk



Wolf Safety Lamp Company



WOLF HAZARD LAMP HL-95

ATEX Directive
94/9/EC
Compliant



- ATEX Certified intrinsically safe “ia” for safe use in Zones 0, 1 or 2
- Flashing or static output selectable from exterior mounted operation switch
- Continuous operation in flashing mode of up to two months, flash rate 60/min
- Daylight cut-out mode selectable from internally mounted switch
- Ultra-bright L.E.D. light source
- 180° bi-directional lens arrangement
- Highlighting obstacles and dangers in the hazardous area
- Effective demarcation of hazardous area zones
- Short term hazardous area warning, ie Road traffic accidents, Petroleum tanker discharge

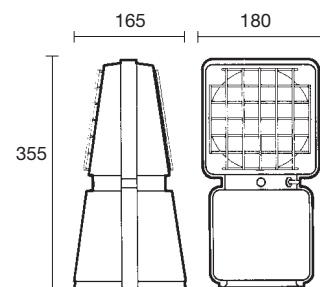

The HL-95 Wolf Hazard Lamp is a semi-portable, free standing illuminated warning device for use in zone 0, 1 or 2 hazardous areas. Approved to the European EN50 range of standards called up in the ATEX Directive for "Electrical Apparatus for Potentially Explosive Atmospheres" and carrying the CE mark with Baseefa (2001) Notified Body number. The Wolf Hazard Lamp is a unique product amongst portable "Ex" lighting equipment.

The HL-95 is powered by an air-depolarised primary cell battery. The use of this battery technology is ideal in such an application due to the exceptionally high capacity available from the relatively small, light weight package size. A single battery, used in the flashing light output mode, provides continuous duration for up to 1500 hours, or two months. In static mode where the lamp is continuously lit, the duration will be up to 500 hours. Operation of the lamp and selection of flashing or static mode is made from a single three position toggle switch mounted on the outside of the lamp. A further extension to the duration of the battery output can be achieved by selecting "daylight cut-out mode" via the internally mounted selection switch. If the lamp is being used out of doors a light dependant resistor will detect when darkness falls and accordingly activate the lamp. Equally, when light levels increase, the lamp will automatically switch off, conserving battery energy. It is estimated that a lamp set to flashing and in daylight cut-out mode could operate for up to six months from a single battery.

The HL-95 has two lenses positioned "back to back". Light is provided by a pair of "everlasting" light emitting diodes. The use of such solid state devices allows the lamp to be sited in zone 0, 1 or 2 hazardous areas. The light emitting diodes are coloured amber as standard or red to special order and are positioned behind a transparent plastic lens, coloured to correspond with the light emitted.

The lens is protected from damage by a stainless steel guard fitted directly to the impact resistant polypropylene lamp body.

Maintenance and user instructions and a lock key are supplied with each lamp.

Wolf HL-95 Safety Hazard Lamp		
Technical Specification		
Product reference	HL-95	
Product description	Primary battery operated safety hazard lamp	
Code	 II 1 G EEx ia IIC T4	
Equipment category	1G	
Apparatus standard	EN50 014, EN50 020	
Type of protection	"ia" intrinsic safety	
Area of classification	Zones 0, 1 and 2, gas groups IIA, IIB and IIC	
Temp. classification	T4	
Ambient temperature	-20°C to +40°C	
Certification	BAS99ATEX1044	
Enclosure	Polypropylene with stainless steel lens guard	
Lens	Transparent plastic, colour as light source	
Light output	≈ 2 cd, comparable to requirements for BS 3143:pt2, Road danger lamps	
Light source:	Type	Solid state L.E.D.
	Colour	Amber as standard, red to order
Power source:	Pt. no.	HL-3155X
	Type	Air-depolarised primary cell battery
	Volts	5.6v
	Capacity	50Ah
	Weight	1.7kg
	Dimensions	L 110 x W 110 x H 140mm
Light duration	1500hrs flashing mode, 500hrs static mode	
Ingress protection	IP 21	
Weight (incl. battery)	2.9kg	

Note: All information has been gathered under laboratory conditions, the user must regard the values given as approximate. The Company reserves the right to alter product specifications without prior notice.

WOLF SAFETY LAMP COMPANY

Saxon Road Works, Sheffield S8 0YA, England

Tel: +44 114 255 1051 Fax: +44 114 255 7988

E-mail: info@wolf-safety.co.uk Website: www.wolf-safety.co.uk

MMD/N/.4.03/6K



Wolf Safety Lamp Company