

Now available from Hawke International
The PL612 Enclosure Populated as a Standard Offering



- **The Ultimate in Robust GRP Construction**
Designed to withstand impact resistance up to 20Nm
GRP Construction provides a high degree of resistance to corrosive atmospheres
- **Anti-Static Properties**
Removes the risk of ignition sources through static induced sparking resistivity
Insulation Resistance in accordance with EN 50014 : 1998, which does not exceed $1 \text{ G}\Omega$
- **External Mounting Feet**
Eliminates the need to remove the lid when mounting the enclosure on the wall
- **Corrosion Resistant Stainless Steel Lid Fixing Screws with Nylon Retaining Washers**
Prevents loss of screws during assembly and maintenance
- **Durable Captive Moulded Silicone Gasket**
Provides Ingress Protection to IP66 and IP67
DTS01 deluge protection witnessed by EECS
- **Stainless Steel Rating Label**
Highly durable and corrosion resistant



Enclosure Type

Glass Reinforced Polyester PL612

Increased Safety EExe

Now available from Hawke International
The NEW ATEX Approved PL612 Enclosure

PL6 Series GRP Enclosures

TERMINAL DATA						
Terminal Manufacturer	Terminal Type	Terminal Quantity	Conductor Size (mm ²)		Max. Volts	Max. Amps
			Min.	Max.		
Weidmuller	WDU 2.5N	12 + 1 Rail Earth	0.5	2.5	420	16
Weidmuller	WDU 2.5	9 + 1 Rail Earth	0.5	2.5	550	19.5

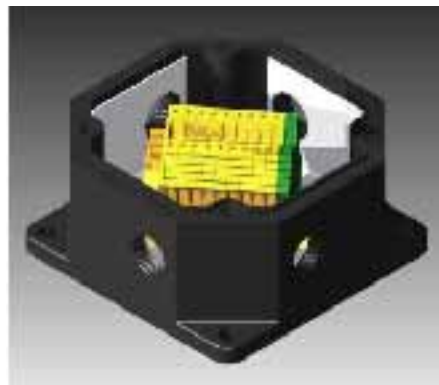
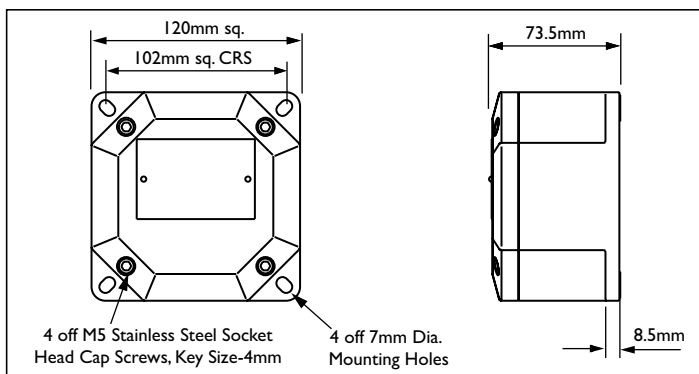

Technical Data

- Increased Safety EExe.
II 2 GD EExe II.
- BASEEFA Certificate No. BAS 01 ATEX 2107X.
- Suitable for use in Zone 1, Zone 2, Zone 21 & Zone 22.
- Construction and test standards EN 50014, EN 50019 and EN 50281-1-1. IEC 60079-0 and IEC 60079-7.
- IP66 and IP67 ingress protection to IEC 60529 and EN 60529.
- DTS01 deluge protection witnessed by EECS.
- Operating temperature range -60°C to +75°C.
- Temperature Class and Ambients T6 40°C.

Materials & Finishes

Glass Reinforced Polyester. Natural Black Finish.
Flame Retardant to IEC 92.1. Clause 2.38.

Please note :-

Hawke still offers enclosures to customer specifications, available from our Box Modifiers

General Information

Standard PL612 Enclosures are supplied complete with :-

- Steel Earth Continuity Plate.
- 1 x M20 offset tapped entry per face. (ENTRIES NOT PLUGGED).

Features

- The Ultimate in Robust GRP Construction
- Anti-Static Properties
- External Mounting Feet
- Corrosion Resistant Stainless Steel Lid Fixing Screws with Nylon Retaining Washers
- Durable Captive Moulded Silicone Gasket
- Stainless Steel Rating Label

To the best of our knowledge the information contained in this leaflet, is accurate at the time of going to print and the company reserves the right to improve or modify any product illustrated without notification. The company is unable to accept liability for any inaccuracies, errors or omissions that may exist. It is the customer's responsibility to ensure that the product is suitable for their application.

All copyright reserved-Hubbell Ltd. This document and all copyright therein is the property of Hawke International a division of Hubbell Ltd. (A member of the Hubbell Group of Companies). Copyright Condition: This document shall be used only for the purpose for which it is provided and no reproduction or publication of the document may be made and no article may be manufactured or assembled in accordance with information contained in the document without prior written consent of the owner.

Smarter products
www.ehawke.com

Hawke International is a division of Hubbell Ltd.
A member of the Hubbell Group of Companies.



Hawke Cable Glands Ltd
Oxford Street West,
Ashton-under-Lyne,
Lancashire OL7 0NA, UK.
Sales: 0870 60 60 105
Tel: +44 (0) 161 308 3611
Fax: +44 (0) 161 308 5848
E-mail: sales@ehawke.com
www.ehawke.com

Hawke Cable Glands America L.C.
600 Kenrick, Suite C-10,
Houston, TX. 77060, USA
Tel: +1 (281) 445 7400
Wats: (800) 354 9189
Fax: +1 (281) 445 7404
E-mail: america@ehawke.com
www.ehawke.com

Hawke Asia-Pacific Pte Ltd
130 Joo Seng Road, #03-02
Olivine Building
Singapore 368357
Tel: 00 65 6282 2242
Fax: 00 65 6284 4244
E-mail: asia@ehawke.com
www.ehawke.com

HAWKE
International

HWK07 Feb '02