

UNIVERSAL BOX

CONTROL BOXES

INDUSTRIAL

A range of lamp control and transformer boxes for Industrial Applications.

This range of boxes replaces the 500 Series Gearbox for the lower wattage range of lamps and are used to supply floodlights without internal gear. Where an ignitor is required it must be fitted in the luminaire. The correction capacitors are in the control box.

The main range is for 150W to 600W HPS lamps.

The transformer box is used for stepping up site voltages from 110/120V to 220/240V. The transformer is designed for voltage transformation and is not suitable for use as an isolated transformer. The rating is 500 and 1000VA. Both the control gear and transformers have a built-in thermal cut-out. This protection is needed for lighting control gear operating during possible lamp faults. This range will often be used as replacements for obsolete items using a variety of lamps. The IOM sent with each product and available on request contains essential information for correct application.

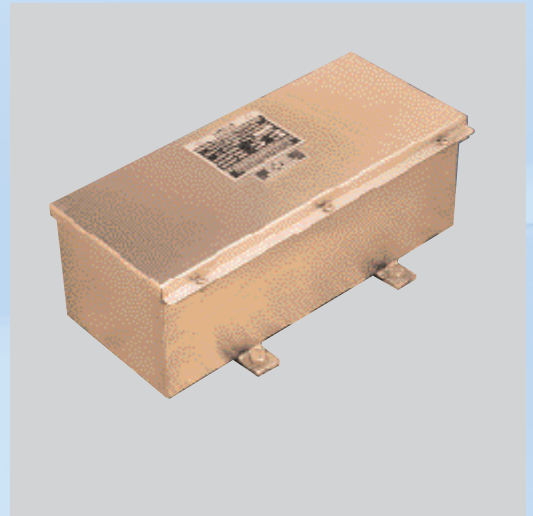

Standard Specification

Ingress Protection:	IP66/67 to EN 60529
Enclosure:	316S31 Marine grade stainless steel with silicone rubber gasket
Entry:	3 x M20 cable entries
Termination:	3 core 6mm ² max. conductor with looping
Installation:	Base mounting straps
Control Gear:	Internal copper/iron and PFC correction capacitor as required
Operating Position:	Cable entries on lower end, if mounted vertically
Electrical Supply:	220-254V 50Hz - Control box version, 120V 50-60Hz 500VA - Transformer box version.

Features

316S31 grade stainless steel construction

Easy to install and maintain

Hinged lid with three captive fixing screws

Lightweight

Control gear easily accessed and can be replaced

Thermal cut-outs fitted on ballast and transformer



Chalmit Lighting, PO BOX 5575, Glasgow G52 9AP
Tel: +44 (0) 141 882 5555 Fax: +44 (0) 141 883 3704
Email: info@chalmit.com
www.chalmit.com

Std. Cat No.	Wattage	Lamp	Weight
UNII/150/MS	150W	HPS/Metal Halide	10.5kg 10.5kg
UNII/250/MS	250W	HPS/Metal Halide	11.5kg 10.5kg
UNII/400/MS	400W	HPS/Metal Halide	12.0kg
UNII/600/HS	600W	HPS	14.0kg 10.5kg
UNII/500/TF	500VA	Transformer	11.0kg 10.5kg

Options - Suffix to Catalogue No.

/___	Specific voltage (254)
/60	60Hz
/M25	M25 Entries
/MF	Mains Fuse
/1000	1000VA Transformer (replace 500 with 1000)
/3P	3 Phase termination

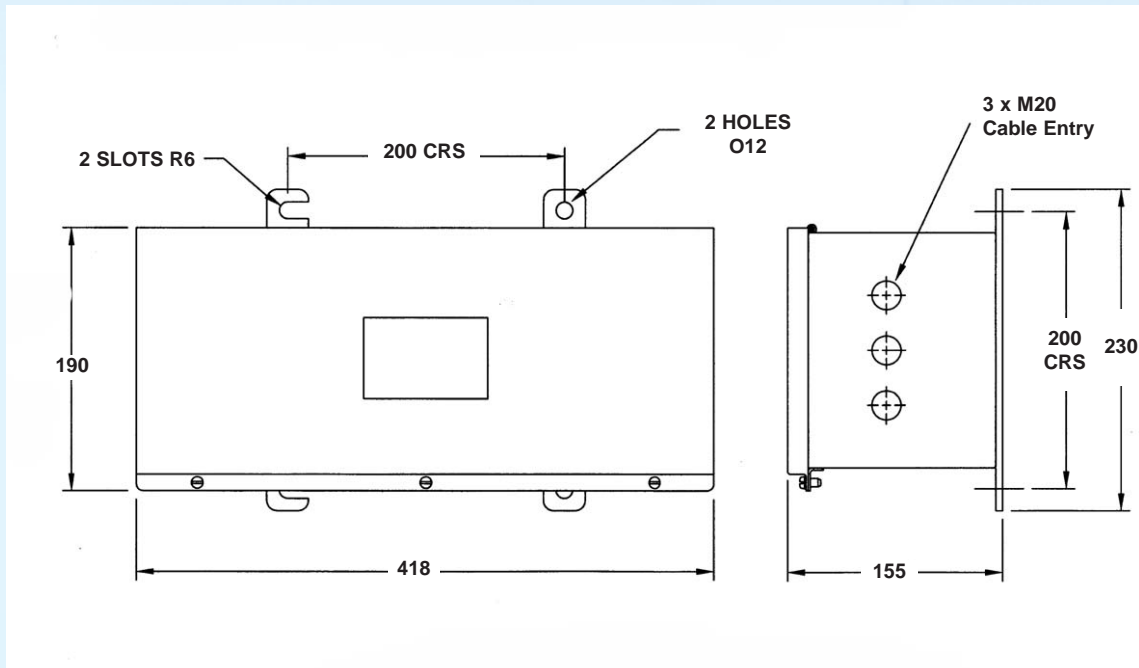

Product design and specification are subject to change without notice.
Please check website for latest specification



Electrical Products

Rev 02 - Sept 2006