

ECLIPSE II

WELLGLASS

INDUSTRIAL

The Eclipse II is a well-glass luminaire suitable for high pressure discharge lamps of up to 400W.

It has a painted lightweight corrosion resistant cast aluminium body and heat resistant glass construction with stainless steel fasteners. It has been tested to IP65 and is suitable for use in harsh environments. The lamp glass has a screwed thread for quick access. The control gear housing hinges on the mounting and termination cover and is held in position by a single screw barrel nut. The single screw barrel nut permits easy access and closure of the luminaire during installation and should maintenance be required. There is a range of wall, surface and stanchion mountings which may be integrated into the design. An enclosed reflector for Highbay applications is also available. A range of external reflectors is available to direct light efficiently to where it is required.



Standard Specification

Ingress Protection:	IP66 to EN60529
Enclosure:	Painted aluminium body with glass lens. Silicone rubber gasket.
Entry:	Single stainless steel barrel nut fastener.
Termination:	4 x M20 cable entries, 3 core 6mm² max, with looping.
Installation:	Ceiling mounting
Lampholder:	E27 or E40
Lamp Type:	HPS, Metal halide, Mercury vapour or QL.
Control Gear:	Internal copper/iron ballast with ignitor and PFC correction capacitors.
Relamping:	Electronic HF for QL. Access via lamp chamber
Burning Position:	Up to 25° off vertical
Electrical Supply:	220, 230, 240V 50Hz (50, 80, 100 & 125W) 220, 230, 240, 254V 50Hz (70, 150, 250 & 400W) 220-240V 50Hz (QL 55 & 85W)

Std. Cat No.	Wattage	Lamp	Lampholder	Weight
EC2I/050/HS	50W	HPS	E27	7.5kg
EC2I/070/MS	70W	HPS/Metal Halide	E27	8.0kg
EC2I/100/HS	100W	HPS	E40	9.0kg
EC2I/150/MS	150W	HPS/Metal Halide	E40	11.0kg
EC2I/250/MS	250W	HPS/Metal Halide	E40	15.0kg
EC2I/400/MS	400W	HPS/Metal Halide	E40	15.5kg
EC2I/080/MV	80W	Mercury Vapour	E27	7.5kg
EC2I/125/MV	125W	Mercury Vapour	E27	8.0kg
EC2I/250/MV	250W	Mercury Vapour	E40	15.0kg
EC2I/400/MV	400W	Mercury Vapour	E40	15.5kg
EC2I/085/QL	85W	QL	QL	8.2kg

Options - Suffix to Catalogue No.

/60	60Hz
/WM	Wall mounted version
/ST	Stanchion mounted version
/PE	Pendant mounted version
/TI	Timed cut out ignitor
/ER	Enclosed spun reflector
/R	Prismatic Refractor

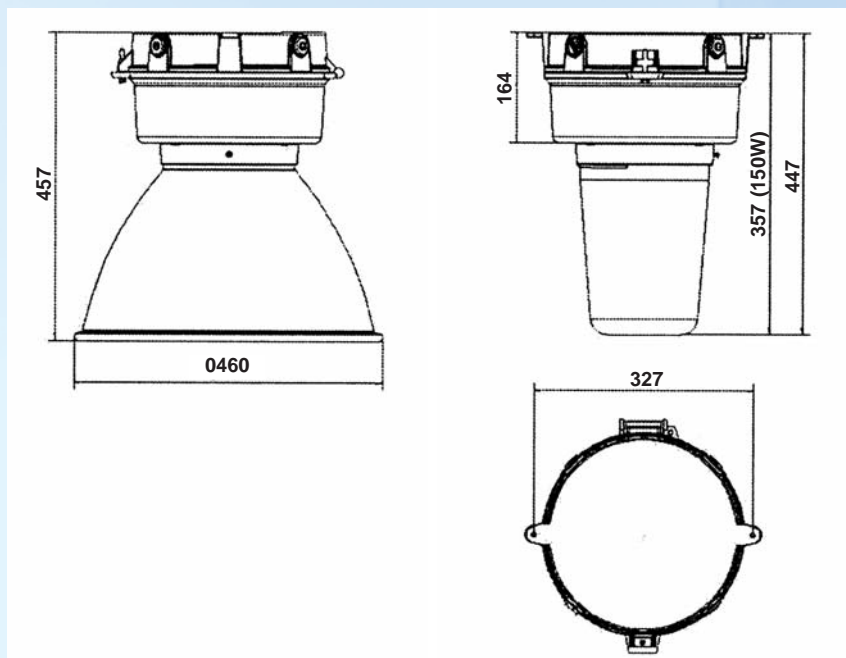

Accessories (Should be ordered separately)

Catalogue Order Code

Wire Guard for low wattage glass globe (Up to 150W)	E0850-0042
Wire Guard for high wattage glass globe (250 & 400W)	E0850-0044
Wire Guard for Enclosed Refractor	E0850-0043
Dome Reflector	SEC20-0001
30° Angled Reflector	SEC20-0002

Product design and specification are subject to change without notice.
Please check website for latest specification



Electrical Products

Rev 02 - Sept 2006