

# CHIEFTAIN

## STREET LANTERN

## INDUSTRIAL

A luminaire specifically designed for clear or diffusing discharge lamps with incorporated control gear.

A main feature of this luminaire is the strength of the enclosure and the very high degree of ingress protection afforded by the simple and reliable construction.

Control gear mounted on removable base plate. High temperature resistant silicon wiring. Cast aluminium door to facilitate access to control gear. Quick release fasteners ensuring that maintenance can be completed quickly and efficiently.

Fixing clamp for posts 42 x 120mm.

Ambient temperature of -36 °C to +40 °C



### Standard Specification

Enclosure:	Body in cast aluminium, polyester powder finish
Diffuser:	Polycarbonate
Reflector:	Removable, high purity aluminium, anodised and highly polished
Installation:	Spigot Entry
Relamping:	Quick release clips
Lampholder:	E40
Ingress Protection:	Bowl IP65 Gear compartment IP54
Burning Position:	Universal
Electrical Supply:	220/230/240/254V 50Hz (HPS/Metal Halide) 220/230/240V 50Hz (MBFU)

Std. Cat No.	Wattage	Lamp Type	Lampholder	Weight
CHFI/150/MS	150	HPS/Metal Halide	E40	10.5kg
CHFI/250/MS	250	HPS/Metal Halide	E40	11.5kg
CHFI/250/MV	250	MBFU	E40	11.5kg

**Options - Suffix to Catalogue No.**

<b>/60</b>	60Hz supply
<b>/TI</b>	Timed Ignitor
<b>/FG</b>	Toughened glass diffuser

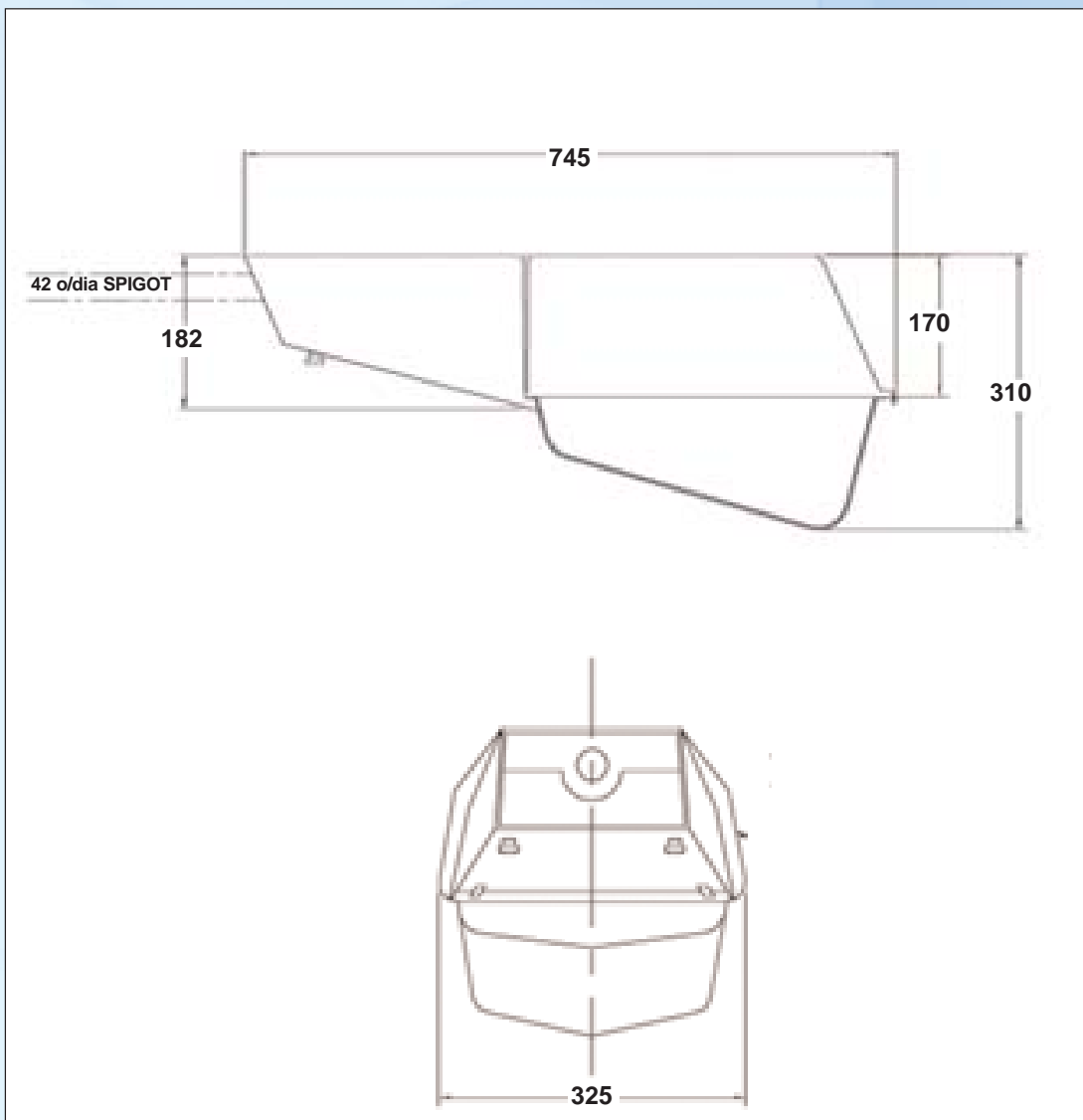

Product design and specification are subject to change without notice.  
Please check website for latest specification



Electrical Products

Rev 02 - Sept 2006