

469

FLOODLIGHT

INDUSTRIAL

The 469 is a high power floodlight for use with 300 to 1000W Tungsten-Halogen lamps. The protection is non-sparking, using a restricted breathing enclosure.

This unique luminaire enables very high wattage lamps to be used for Industrial applications. The floodlight is fully weatherproof and is made from corrosion resistant aluminium and toughened glass with a silicone rubber gasket seal.

Through advanced design and construction techniques the surface temperature remains relatively low even at maximum lamp wattage.

The 469 is used where high instant illumination is needed and can be used with 120V or dc supplies.



Standard Specification

Enclosure:	Marine grade aluminium alloy LM6 body with toughened glass window, silicone rubber gasket
Reflector:	Wide beam high purity anodised aluminium
Entry:	M20 cable entry
Termination:	3 core 4mm² max. conductor
Installation:	Foot mounted
Relamping:	Access via front glass cover assembly secured by stainless steel screws
Lampholder:	E40
Burning Position:	Universal
Electrical Supply:	Up to 250V ac/dc

Features

Very robust

Highly resistant to corrosion and mechanical damage

All stainless steel fasteners

Suspended hinged front cover assembly

Compact

ATEX version available



United Kingdom Tel: +44 (0) 141 882 5555
Benelux Tel: +31 (0) 302 467 132
Abu Dhabi Tel: +971 2621 3496
Dubai Tel: +971 4334 2823
Singapore Tel: +65 6282 2242

Fax: +44 (0) 141 883 3704
Fax: +31 (0) 302 467 133
Fax: +971 2631 2152
Fax: +971 4334 7974
Fax: +65 6284 4244

Email: info@chalmit.com
Email: jdm.van.straalen@planet.nl
Email: rwood@emirates.net.ae
Email: albertmf@emirates.net.ae
Email: chalmits@singnet.com.sg

Std. Cat No.	Wattage	Lamp	Lampholder	T Class	Ambient°C	Weight
469I/300/TH	300W	Single Ended T/Halogen	E40	T3	50	10.0kg
469I/500/TH	500W	Single Ended T/Halogen	E40	T3	40	10.0kg
469I/1000/TH	1000W	Single Ended T/Halogen	E40	T2	40	10.0kg

Options - Suffix to Catalogue

/PM Pole mounted version

/P PTFE coating

/N Narrow beam reflector

/M25 M25 Entry

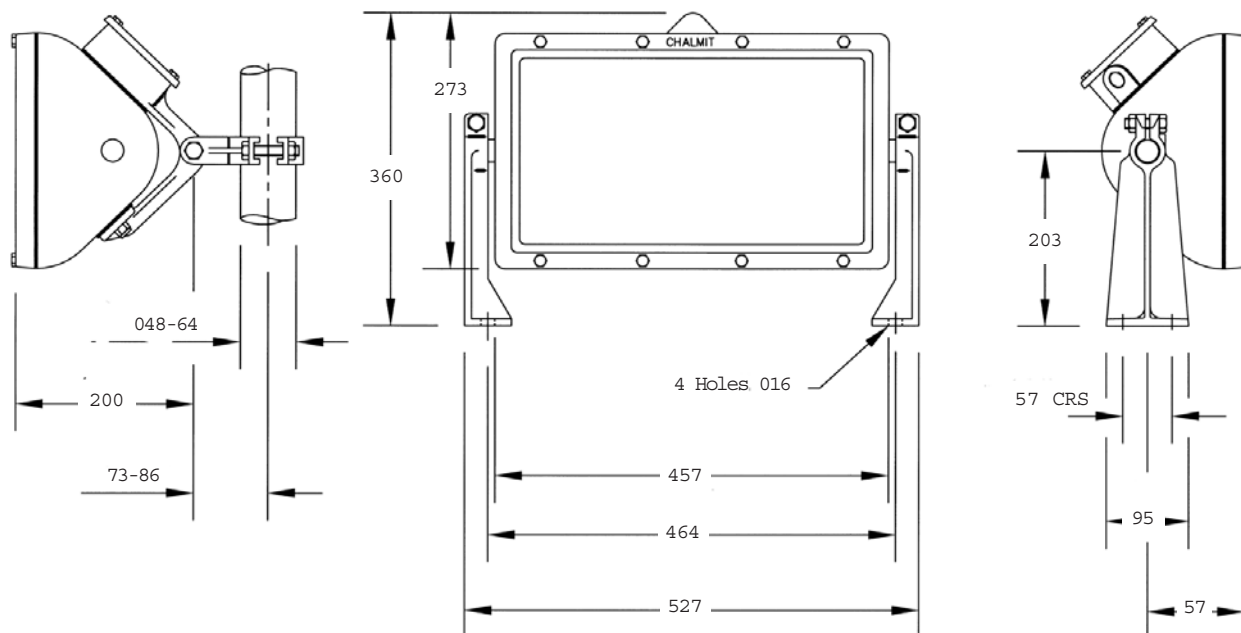

Accessories (Should be ordered separately)

Catalogue Order Code

Anti-glare shield

S4000-0002

Wire guard

E0850-0002

Swinging Jib assembly

S2000-0019



United Kingdom Tel: +44 (0) 141 882 555
 Benelux Tel: +31 (0)302 467 132
 Abu Dhabi Tel: +971 2621 3496
 Dubai Tel: +971 4334 2823
 Singapore Tel: +65 6282 2242

Fax: +44 (0) 141 883 3704
 Fax: +31 (0) 302 467 133
 Fax: +971 2631 2152
 Fax: +971 4334 7974
 Fax: +65 6284 4244

Email: info@chalmit.com
 Email: john.van.straalen@planet.nl
 Email: rwood@emirates.net.ae
 Email: albertmf@emirates.net.ae
 Email: chalmits@singnet.com.sg