

PROTECTA

NORMAL and EMERGENCY LIGHTING Ex n FLUORESCENT

The Protecta Category 3 Ex n luminaire combines the strength and integrity of the Category 2 increased safety enclosure with the Category 3 lamp and control gear package used in the Sterling.

The range is suitable for T8 tubular fluorescent lamps in the nominal 18W and 36W sizes.

Protecta has excellent maintenance features as it is constructed using glass reinforced polyester (GRP) and polycarbonate which resist saline and other corrosive environments. A major feature of the luminaire is the strength of the enclosure and mounting points together with the very high degree of ingress protection afforded by the simple reliable construction.

The protection is Ex n with IP66/67 sealing for ignitable gas and dust applications. The Protecta is certified under the ATEX 94-9-EC directive for Categories 3 G and 3 D.

Easy of access to lamps and control gear means that installation and maintenance will be completed quickly and efficiently. The Protecta offers the facility of four cable entries. The standard range has electronic control gear. Conventional low loss control gear with electronic start is available as an option. An emergency version with 3 hour duration is available.



Standard Specification

Features

Type of Protection	Ex nA (Non-sparking) Dust protected enclosure
ATEX Classification	Group II Category 3 G D
Area Classification	Zone 2 and Zone 22 areas to EN 60079-10 and EN 50281-3 with installation to EN 60079-14 and EN 50281-1-2
Apparatus Standard	EN 50021 EN 50281-1-1
Certificate Coding	EC Type Examination Certificate BAS01ATEX3276 ⊕ II 3 G D EEx nA (refer to table for T rating and Ambient)
Enclosure	GRP body with polycarbonate cover and brass suspension points
Reflector Entry Termination	White polyester painted zinc coated steel 4 x M20 cable entries, 2 at each end 3 core 6mm ² max. conductor with looping and 16A rating through wiring (4 core on emergency)
Installation	Two M8 tapped brass inserts located on rear of body. (thread depth 12mm)
Lampholder Lamp Type	G13 (Bi-pin) T8 tubular fluorescent
Control Gear	High Frequency ballast housed within sealed enclosure, Emergency - electronic charger/inverter housed in sealed enclosure, Ni-Cd batteries
Relamping Burning Position	Quick release diffuser clamp and hinged cover Universal
Ingress Protection	IP66/67 to EN 60529
Electrical Supply	220-240V 50/60Hz
Battery Duration	Ni-Cd battery 6V/4Ah 3 hours
Emergency Output	10% of one lamp

Full length easy access diffuser clamp
Simple rugged construction
Hinged cover
DTS-01 deluge tested
Standard fixing centres
High frequency control gear gives 50/60Hz operation, high power factor correction and regulation of lamp output
Easy access to suspended control gear tray

ATEX CATEGORY 3 ZONE 2 & 22 APPLICATIONS

Std. Cat No.	Wattage	T Class (Gas)	T°C (Dust)	Ambient °C	Weight
PRGN/118/BI	1x18W	T4*	95	50	5.9kg
PRGN/218/BI	2x18W	T4*	95	50	6.2kg
PRGN/136/BI	1x36W	T4*	95	50	9.6kg
PRGN/236/BI	2x36W	T4*	95	50	10.0kg
PRGN/136/BI/EM	1x36W	T4*	95	50	12.2kg
PRGN/236/BI/EM	2x36W	T4*	95	50	12.6kg

* T class and ambients vary for copper and iron control gear. Contact Chalmit sales for details.

Options - Suffix to Catalogue No.

- /___ Specific voltage (220 or 254 only available with copper & iron gear)
- /ES Copper and iron control gear (Non-emergency only)
- /60 60Hz (copper and iron versions only)
- /M25 M25 Entries
- /3P Three phase termination
- /MF Mains fuse
- /IS Isolation switch (coding EEx nC IIC)

Applications

Zone 2 hazardous areas
 Petrochemical process areas
 Sewage treatment plants
 Process skid manufacturing
 Distilleries
 Gantry and walkway lighting

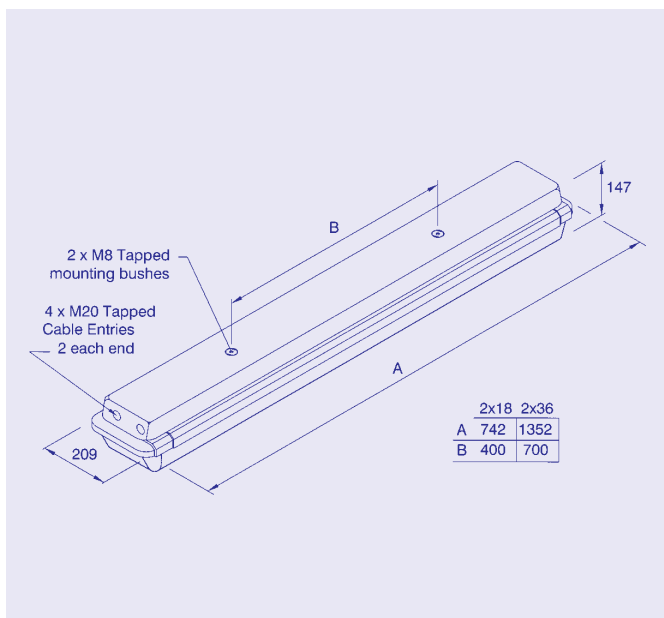

Accessories (Should be ordered separately)

Catalogue Order Code

Offset ceiling bracket assembly	SPRO4-0002
Pole mounting bracket assembly (38/50 diameter poles)	SPRO4-0003
C' form hook type ceiling bracket assembly	SPRO4-0005
Flush mounted wall bracket assembly	SPRO4-0006
18W wall mounting outreach bracket (use with SPRO4-0003)	NPRO4-0008
36W wall mounting outreach bracket (use with SPRO4-0003)	NPRO4-0012
Eyebolt brackets (set)	SPRO5-0005
Looping Kit (Allows looping from both ends of luminaire)	SPROT-0021

Product design and specifications are subject to change without notice, please check the Chalmit website for latest specifications.